

SINGER
9800/5017/5028/5040/CP17

PAR . LIST
9800,5017,CP-17,5028,5040
REVISION RECORD

REV.	DESCRIPTION	APPROVAL AND DATE
	ADOPT.	L.F.GONZAGA DEC/98

From the library of: Diamond Needle Corp

INDEX

PAGE NBR.

SUB-ASSEMBLY

01 , 02	ATTACHMENT SET
03 , 04	ADDITIONAL ACCESSORES (OVER-THE-COUNTER)
05 , 06	ARM, BED, THROAT PLATE & BED SLIDE
07 , 08	ARM, TOP COVER
09 , 10	COVERS & ADD-ONS
11 , 13	NEEDLE BAR
14 , 15	PRESSER BAR
16 , 17	ARM SHAFT DRIVE
18 , 19	HAND WEEL
20 , 21	TENSION MECHANISM
22 , 23	HOOK SYSTEM
24 , 25	BIGHT AMPLITUDE
26 , 29	NEEDLE POSITION
30 , 31	PATTERN SELECTOR
32 , 33	CAM STACK
34 , 35	FEED REGULATOR CAM
36 , 37	BUTTONHOLER & FEED REGULATOR CAM
38 , 39	CAM CONTROLLED FEED
40 , 41	FEED SYSTEM
42 , 46	ELECTRICAL EQUIPMENT

From the library of: Diamond Needle Corp

ATTACHMENT SET

9

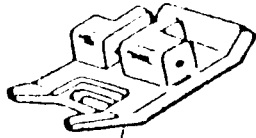

1

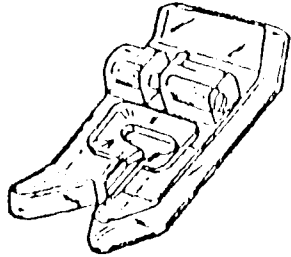

2



3

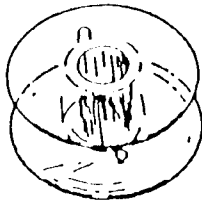

4

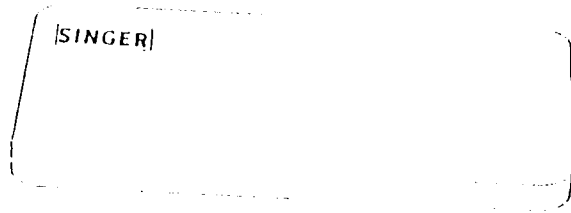

11

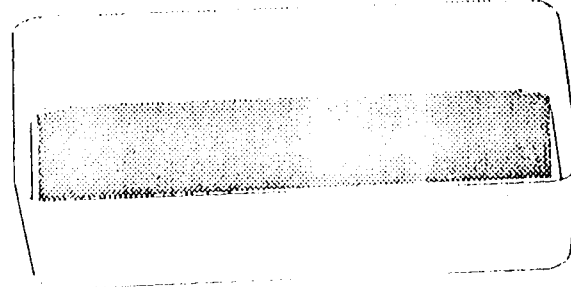

12

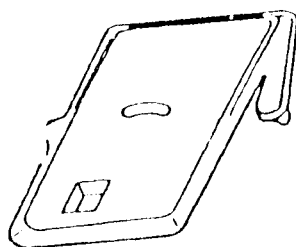

6

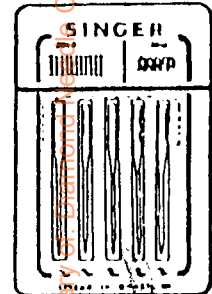

5



10

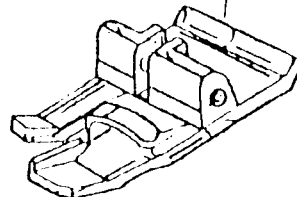

8



7

From the library of the Singer Sewing Machine Corp

REV. _____
DATE DEC/98

PARTS LIST
ATTACHMENT SET

9 9 9 5 C 9 9 9 9 9 9 5 9 9 9 5 9 9 9
8 8 8 0 P 8 8 8 8 8 8 0 8 8 8 0 8 8 9
0 0 0 1 1 0 0 1 1 1 1 2 1 2 2 4 3 3 3
2 3 5 7 7 6 8 0 2 4 6 8 8 4 8 0 2 6 6

REF.PART NBR

DESCRIPTION

REF.PART NBR	DESCRIPTION	2	3	5	7	7	6	8	0	2	4	6	8	8	4	8	0	2	6	6
01 446492-451	SPECIAL PURPOSE PRESSER FOOT PLATE (SNAP-ON)	-	-	X	X	X	X	X	X	X	X	X	X	X	X	X	X	X	X	X
02 161927	PRESSER FOOT PLATE (SNAP-ON) FOR SEWING BUTTONHOLES	-	-	X	X	X	X	X	X	X	X	X	X	X	X	X	X	X	X	X
03 507836	PRESSER FOOT PLATE (SNAP-ON) COMPLETE FOR CORDING & SLIDE FASTENERS	-	-	X	X	X	X	X	X	X	X	X	X	X	X	X	X	X	X	X
04 172336	BOBBIN (PLASTIC)	X	X	X	X	X	X	X	X	X	X	X	X	X	X	X	X	X	X	X
05 353364	NEEDLE PACK (INCLUDES 1 EA. N2020 SIZE 11/14/15 & N2045 SIZE 11/14)	X	X	X	X	X	X	X	X	X	X	X	X	X	X	X	X	X	X	X
06 313117	FEED COVER PLATE (PLASTIC)	X	X	X	X	X	X	X	X	X	X	X	X	X	X	X	X	X	X	X
07 507664-467	ARM TOP COVER SPOOL PIN THREAD LEAD-OFF (SMALL PLASTIC)	X	X	X	X	X	X	X	X	X	X	X	X	X	X	X	X	X	X	X
08 356630	BLIND STITCH GUIDE	-	-	X	X	X	X	X	X	X	X	X	X	X	X	X	X	X	X	X
09 357031	ATTACHMENT SET COMPLETE	X	X	-	-	-	-	-	-	-	-	-	-	-	-	-	-	-	-	-
09 357030	ATTACHMENT SET COMPLETE	-	-	X	X	X	X	X	X	X	X	X	X	X	X	X	X	X	X	X
09 446496-003	ATTACHMENT BOX COMPLETE	-	-	-	-	-	-	-	-	-	-	-	-	-	-	-	-	-	-	X
10 179967-461	ARM TOP COVER SPOOL PIN THREAD LEAD-OFF	X	X	X	X	X	X	X	X	X	X	X	X	X	X	X	X	X	X	X
11 446149-458	ATTACHMENT BOX COVER (PLASTIC)	-	-	-	-	-	-	-	-	-	-	-	-	-	-	-	-	-	-	X
12 446148-456	ATTACHMENT BOX BASE (PLASTIC)	-	-	-	-	-	-	-	-	-	-	-	-	-	-	-	-	-	-	X

From the library of Diamond Needle Corp

ADDITIONAL ACCESSORIES (OVER-THE-COUNTER)

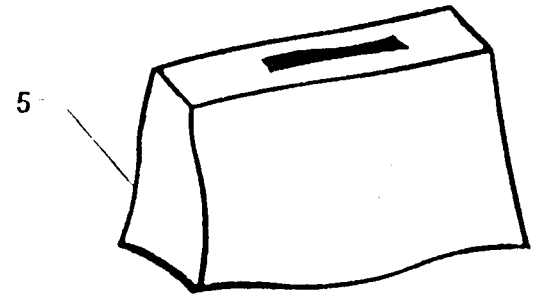
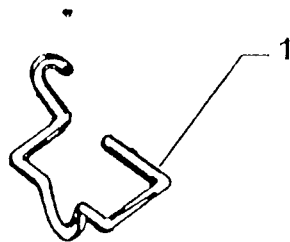
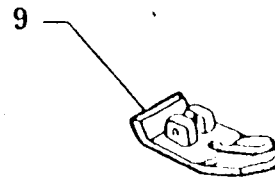
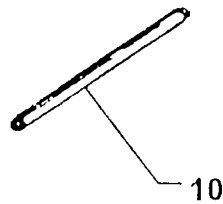
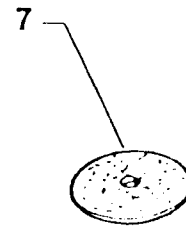
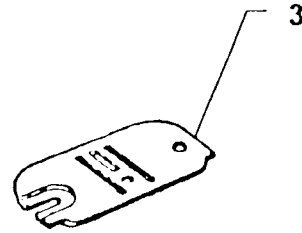
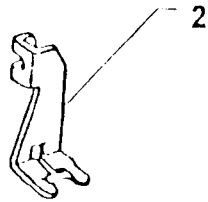

REV: _____
DATE: DEC/98

**PART LIST
ADDITIONAL ACCESSORIES
OVER-THE-COUNTER**

9 9 9 5 C 9 9 9 9 9 9 5 9 9 9 5 9 9 9
8 8 8 0 P 8 8 8 8 8 8 0 8 8 8 0 8 8 9
0 0 0 1 1 0 0 1 1 1 1 2 1 2 2 4 3 3 3
2 3 5 7 7 6 8 0 2 4 6 8 8 4 8 0 2 6 6

REF. PART NBR

DESCRIPTION

01 116863	FINGER GUARD	X X
02 179911	PRESSER FOOT FOR BUTTON SEWING	X X
03 313066	NEEDLE PLATE FOR STRAIGHT STITCH SEWING	X X
05 356392-452	DUST COVER (SOFT VINYL)	X X
06 357004-001	OIL CONTAINER COMPLETE	X X
07 8879-656	SPOOL PIN FELT FOR TWIN NEEDLE	X X
08 531868	NEEDLE PACK (ONE TWIN NEEDLE 2025-14)	X X
09 153267	PRESSER FOOT PLATE (SNAP-ON) FOR STRAIGHT STITCH	X X
10 356942-453	SPOOL PIN FOR TWIN NEEDLE	X X

From the library of: Diamond Needle Corp.

ARM, BED, THROAT PLATE & BED SLIDE

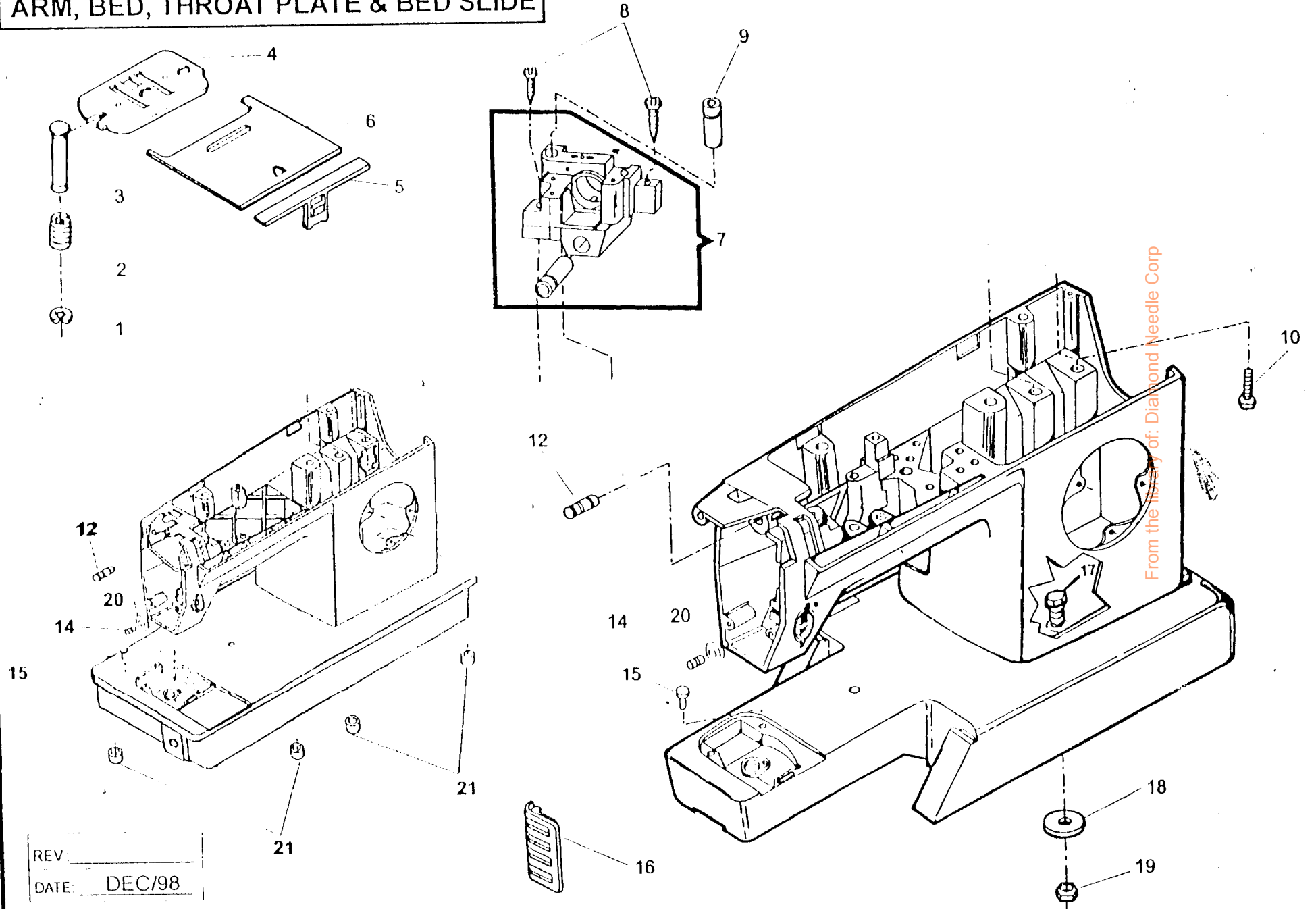

REV: _____
DATE: DEC/98

PART LIST
ARM, BED, THROAT PLATE & BED SLIDE

9 9 9 5 C 9 9 9 9 9 9 5 9 9 9 5 9 9 9
 8 8 8 0 P 8 8 8 8 8 8 0 8 8 8 0 8 8 9
 0 0 0 1 1 0 0 1 1 1 1 2 1 2 2 4 3 3 3
 2 3 5 7 7 6 8 0 2 4 6 8 8 4 8 0 2 6 6

REF.PART NBR

DESCRIPTION

01	179926	THROAT PLATE CLAMP SPRING RETAINING RING	X	X	X	X	X	X	X	X	X	X	X	X	X	X	X	X	X
02	357611	THROAT PLATE CLAMP SPRING	X	X	X	X	X	X	X	X	X	X	X	X	X	X	X	X	X
03	353597	THROAT PLATE CLAMP	X	X	X	X	X	X	X	X	X	X	X	X	X	X	X	X	-
03	357445	THROAT PLATE CLAMP	-	-	-	-	-	-	-	-	-	-	-	-	-	-	-	-	X
04	356713	THROAT PLATE FOR ZIG-ZAG SEWING	X	X	X	X	X	X	X	X	X	X	X	X	X	X	X	X	X
05	446482	BED SLIDE SPRING (SNAP-ON)	X	X	X	X	X	X	X	X	X	X	X	X	X	X	X	X	X
06	356715	BED SLIDE	X	X	X	X	X	X	X	X	X	X	X	X	X	X	X	X	-
06	179982	BED SLIDE	-	-	-	-	-	-	-	-	-	-	-	-	-	-	-	-	X
07	357017-002	ARM SHAFT (REAR) HOUSING ASSEMBLY	X	X	X	X	X	X	X	X	X	X	X	X	X	X	X	X	X
08	113455-006	ARM SHAFT (REAR) HOUSING MOUNTING SCREW	X	X	X	X	X	X	X	X	X	X	X	X	X	X	X	X	X
09	357019	ARM TOP COVER SUPPORT STUD	X	X	X	X	X	X	X	X	X	X	X	X	X	X	X	X	X
10	357020-451	ARM SHAFT (REAR) HOUSING MOUNTING BOLT	X	X	X	X	X	X	X	X	X	X	X	X	X	X	X	X	X
12	446375	THREAD TAKE-UP LEVER LINK HINGE STUD	X	X	X	X	X	X	X	X	X	X	X	X	X	X	X	X	X
14	357438-001	TENSION RELEASING LEVER HINGE PIN	X	X	X	X	X	X	X	X	X	X	X	X	X	X	X	X	X
15	353624	THROAT PLATE POSITION PIN	X	X	X	X	X	X	X	X	X	X	X	X	X	X	X	X	X
16	356957-900	ARM INSERT MOTOR VENT GRILL	X	X	X	X	X	X	X	X	X	X	X	X	X	X	X	X	-
17	355250-451	BED (BOTTOM) COVER & GABINET BOLT	X	X	X	X	X	X	X	X	X	X	X	X	X	X	X	X	-
18	353375-451	BED (BOTTOM) COVER & GABINETE BOLT WASHER	X	X	X	X	X	X	X	X	X	X	X	X	X	X	X	X	-
19	514608	BED (BOTTOM) COVER & GABINET BOLT NUT	X	X	X	X	X	X	X	X	X	X	X	X	X	X	X	X	-
20	357464-002	TENSION RELEASING LFVER HINGE PIN WASHER	X	X	X	X	X	X	X	X	X	X	X	X	X	X	X	X	X
21	353559-451	UNDER BED COVER CUSHION																	

From the library of: Diamond Needle Corp

REF.	NEW P/N	IN PLACE OF	IMPLEMENTATION DATE
02	357611	353494	04/14/97
04	356713	312777	07/17/95
06	356715	446481	07/17/95
07	357017-002	446347-002	02/03/94
09	357019	446465-001	02/03/94
10	357020-451	446349-451	02/03/94
14	357438-001	446358	02/21/97
20	357464-002	-----	01/03/98

9800 series, 5017 model, CP-17 model, 5028 and 5040 model.
 P/N 357669-001

Adopt.

ARM TOP COVER

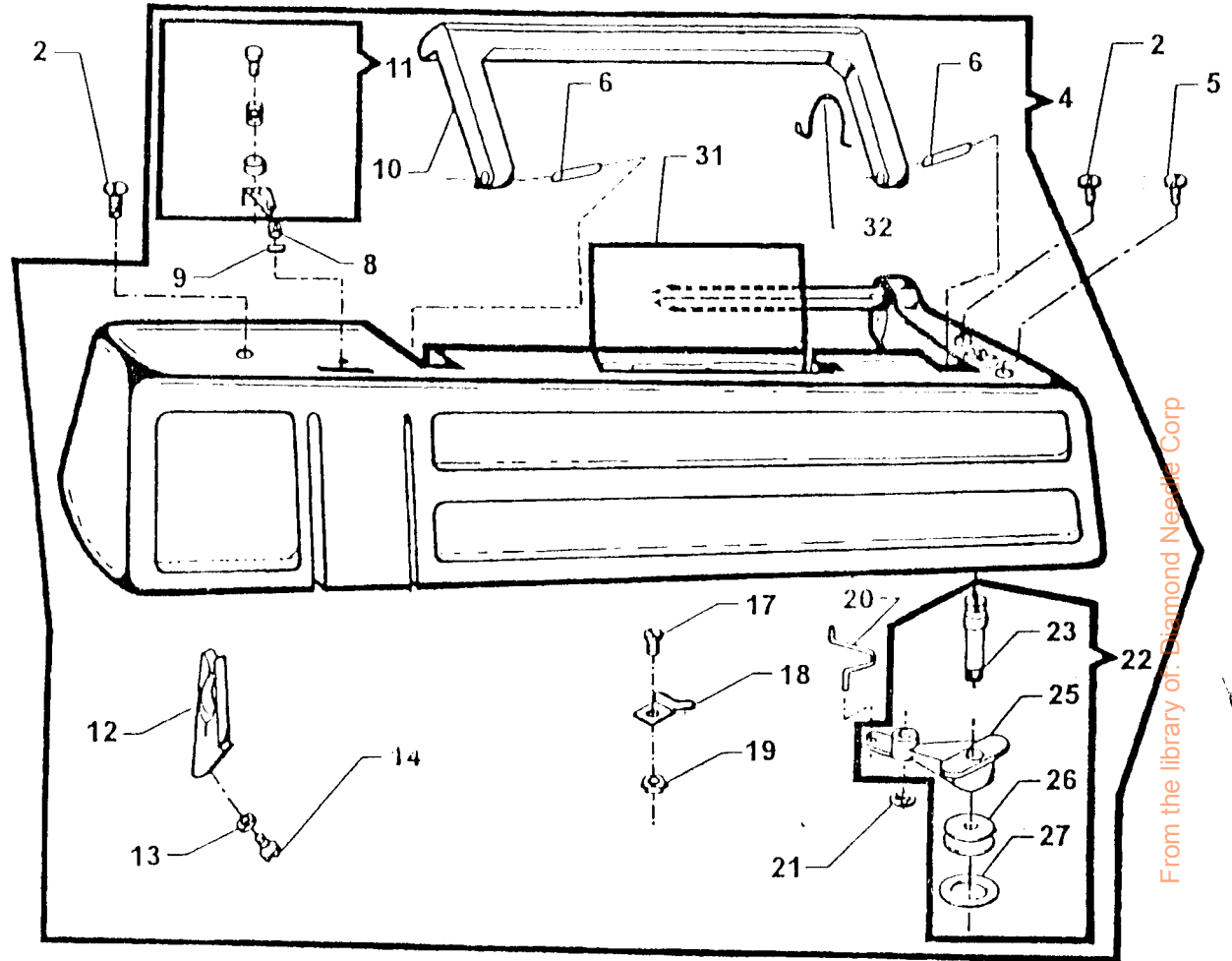
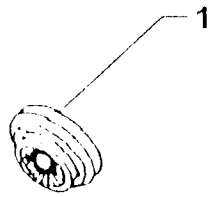

From the library of: Diamond Needle Corp

REV: _____
DATE: DEC/98

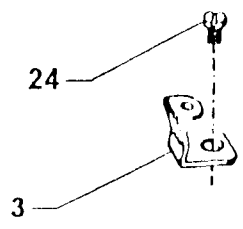
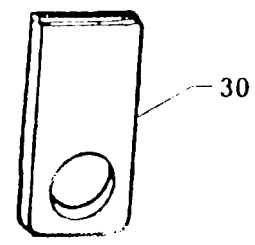
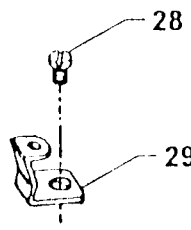

**PART LIST
ARM TOP COVER**

REF.PART NBR	DESCRIPTION	9	9	9	5	C	9	9	9	9	9	9	5	9	9	9	5	9	9	9	5	9	9	9	5	9	9	9	
		8	8	8	0	P	8	8	8	8	8	8	0	8	8	8	0	8	8	8	0	8	8	8	0	8	8	8	9
		0	0	0	1	1	0	0	1	1	1	1	2	1	2	2	4	3	3	3									
		2	3	5	7	7	6	8	0	2	4	6	8	8	4	8	0	2	6	6									
01 179967-461	ARM TOP COVER THREAD LEAD OFF (LARGE)	X	X	X	X	X	X	X	X	X	X	X	X	X	X	X	X	X	X	X	X	X	X	X	X	X	X	X	
02 354895-453	ARM TOP COVER SCREW	X	X	X	X	X	X	X	X	X	X	X	X	X	X	X	X	X	X	X	X	X	X	X	X	X	X	X	
03 353343	ARM TOP COVER MOUNTING BRACKET (RIGHT)	X	X	X	X	X	X	X	X	X	X	X	X	X	X	X	X	X	X	X	X	X	X	X	X	X	X	X	
04 356990-XXX	ARM TOP COVER COMPLETE	-	-	-	-	-	-	-	-	-	-	-	-	-	-	-	-	-	-	-	-	-	-	-	-	-	-	-	
05 354975-451	ARM TOP COVER SCREW (RIGHT,FRONT)	X	X	X	X	X	X	X	X	X	X	X	X	X	X	X	X	X	X	X	X	X	X	X	X	X	X	X	
06 357325-900	ARM TOP COVER MACHINE HANDLE HINGE PIN	X	X	X	X	X	X	X	X	X	X	X	X	X	X	X	X	X	X	X	X	X	X	X	X	X	X	X	
08 141936-833	BOBBIN WINDER TENSION BRACKET ADJUSTING SCREW	X	X	X	X	X	X	X	X	X	X	X	X	X	X	X	X	X	X	X	X	X	X	X	X	X	X	X	
09 44794	BOBBIN WINDER TENSION BKT ADJUSTING SCREW RET.CLIP	X	X	X	X	X	X	X	X	X	X	X	X	X	X	X	X	X	X	X	X	X	X	X	X	X	X	X	
10 357329-900	ARM TOP COVER MACHINE HANDLE	X	X	X	X	X	X	X	X	X	X	X	X	X	X	X	X	X	X	X	X	X	X	X	X	X	X	X	
11 356047	BOBBIN WINDER TENSION COMPLETE	X	X	X	X	X	X	X	X	X	X	X	X	X	X	X	X	X	X	X	X	X	X	X	X	X	X	X	
12 357084-451	ARM TOP COVER THREAD GUIDE	X	X	X	X	X	X	X	X	X	X	X	X	X	X	X	X	X	X	X	X	X	X	X	X	X	X	X	
13 446138	ARM TOP COVER THREAD GUIDE SCREW WASHER	X	X	X	X	X	X	X	X	X	X	X	X	X	X	X	X	X	X	X	X	X	X	X	X	X	X	X	
14 356116-451	ARM TOP COVER THREAD GUIDE SCREW	X	X	X	X	X	X	X	X	X	X	X	X	X	X	X	X	X	X	X	X	X	X	X	X	X	X	X	
17 141920-455	BOBBIN WINDER STOP SCREW	X	X	X	X	X	X	X	X	X	X	X	X	X	X	X	X	X	X	X	X	X	X	X	X	X	X	X	
18 445924	BOBBIN WINDER STOP	X	X	X	X	X	X	X	X	X	X	X	X	X	X	X	X	X	X	X	X	X	X	X	X	X	X	X	
19 53640-819	BOBBIN WINDER STOP SCREW NUT	X	X	X	X	X	X	X	X	X	X	X	X	X	X	X	X	X	X	X	X	X	X	X	X	X	X	X	
20 531766	BOBBIN WINDER HINGE STUD SPRING	X	X	X	X	X	X	X	X	X	X	X	X	X	X	X	X	X	X	X	X	X	X	X	X	X	X	X	
21 445486	BOBBIN WINDER RETAINING RING	X	X	X	X	X	X	X	X	X	X	X	X	X	X	X	X	X	X	X	X	X	X	X	X	X	X	X	
22 531767-452	BOBBIN WINDER ASSEMBLY	X	X	X	X	X	X	X	X	X	X	X	X	X	X	X	X	X	X	X	X	X	X	X	X	X	X	X	
23 357081-452	BOBBIN WINDER SPINDLE COMPLETE	X	X	X	X	X	X	X	X	X	X	X	X	X	X	X	X	X	X	X	X	X	X	X	X	X	X	X	
24 113455-001	ARM TOP COVER MOUNTING BRACKET SCREW	X	X	X	X	X	X	X	X	X	X	X	X	X	X	X	X	X	X	X	X	X	X	X	X	X	X	X	
25 357082-452	BOBBIN WINDER FRAME	X	X	X	X	X	X	X	X	X	X	X	X	X	X	X	X	X	X	X	X	X	X	X	X	X	X	X	
26 44440-001	BOBBIN WINDER PULLEY	X	X	X	X	X	X	X	X	X	X	X	X	X	X	X	X	X	X	X	X	X	X	X	X	X	X	X	
27 15287-701	BOBBIN WINDER FRICTION RING (RUBBER)	X	X	X	X	X	X	X	X	X	X	X	X	X	X	X	X	X	X	X	X	X	X	X	X	X	X	X	
28 354826-451	ARM TOP COVER MOUNTING BRACKET SCREW	X	X	X	X	X	X	X	X	X	X	X	X	X	X	X	X	X	X	X	X	X	X	X	X	X	X	X	
29 531765	ARM TOP COVER MOUNTING BRACKET (LEFT)	X	X	X	X	X	X	X	X	X	X	X	X	X	X	X	X	X	X	X	X	X	X	X	X	X	X	X	
30 357008-451	ARM TOP COVER SHROUD	X	X	X	X	X	X	X	X	X	X	X	X	X	X	X	X	X	X	X	X	X	X	X	X	X	X	X	
31 356954-451	ARM TOP COVER LID (WITH GRAPHICS)	-	-	-	-	-	-	-	-	-	-	-	-	-	-	-	-	-	-	-	-	X	X	X	X	X	X	X	
31 356954-900	ARM TOP COVER LID (WITHOUT GRAPHICS)	X	X	X	X	X	X	X	X	X	X	X	X	X	X	X	X	X	X	X	X	X	X	X	X	X	X	X	
32 357002	ARM TOP COVER LID SPRING	X	X	X	X	X	X	X	X	X	X	X	X	X	X	X	X	X	X	X	X	X	X	X	X	X	X	X	

From the library of: Diamond Needle Corp.

NOTE: PLEASE WHEN NEED THE PART NUMBER(-----XXX), INDICATE THE MACHINE MODEL WHERE WILL BE USED.

9800 series, 5017 model, CP-17 model, 5026 and 5040 model.
P/N 357669-001

Adpot

COVERS & ADD-ONS

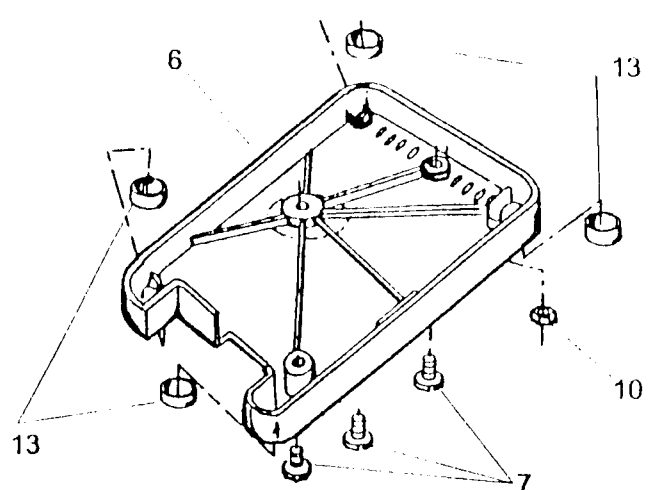
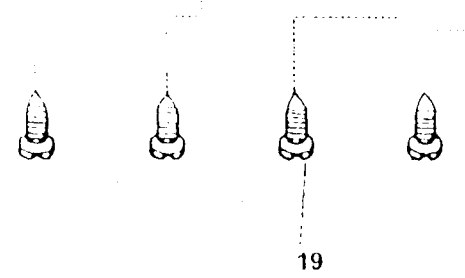
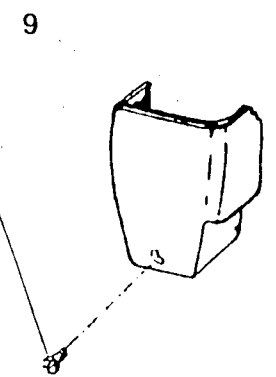
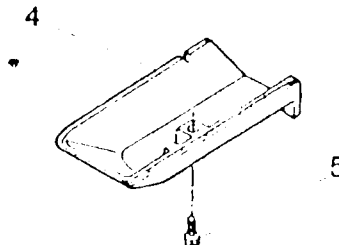
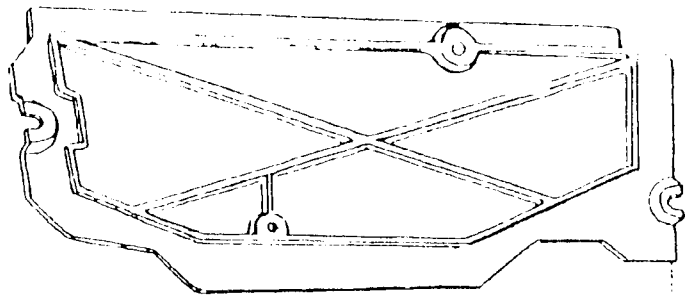
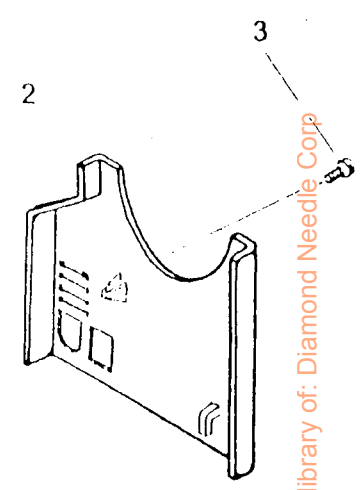
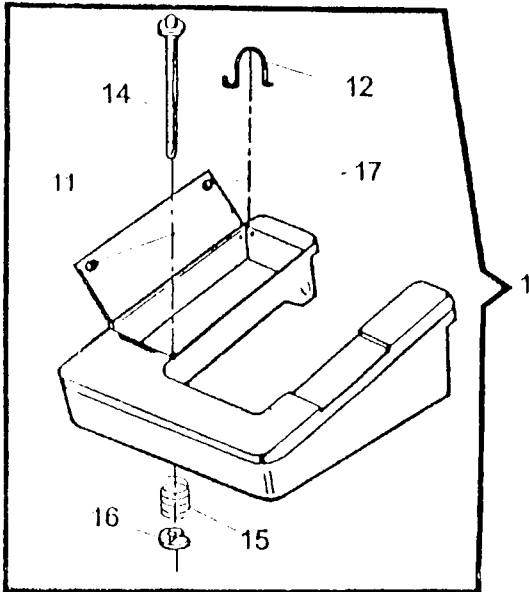

REV: _____
DATE DEC/98

From the library of: Diamond Needle Corp

PARTS LIST
COVERS & ADD-ONS

9	9	9	5	C	9	9	9	9	9	9	5	9	9	9	5	9	9	9	9		
8	8	8	0	P	8	8	8	8	8	8	0	8	8	8	0	8	8	0	8	8	9
0	0	0	1	1	0	0	1	1	1	1	2	1	2	2	4	3	3	3	3	3	3
2	3	5	7	7	6	8	0	2	4	6	8	8	4	8	0	2	6	6	6	6	6

REF.PART NBR

DESCRIPTION

01	356989-451	BED EXTENSION PLATE	X	X	X	X	X	X	X	X	X	X	X	X	X	X	X	X	X	X	X	-
02	356953-XXX	ARM END COVER	-	-	-	-	-	-	-	-	-	-	-	-	-	-	-	-	-	-	-	-
03	364063-451	ARM END COVER SCREW	X	X	X	X	X	X	X	X	X	X	X	X	X	X	X	X	X	X	X	-
04	446493-453	BED (TUBULAR) BOTTOM COVER (PLASTIC)	X	X	X	X	X	X	X	X	X	X	X	X	X	X	X	X	X	X	X	-
05	354895-453	BED (TUBULAR) BOTTOM COVER FASTENING SCREW	X	X	X	X	X	X	X	X	X	X	X	X	X	X	X	X	X	X	X	-
06	356929-451	BED (BOTTOM) COVER (PLASTIC)	X	X	X	X	X	X	X	X	X	X	X	X	X	X	X	X	X	X	X	-
07	113455-001	BED (BOTTOM) COVER FASTENING SCREW	X	X	X	X	X	X	X	X	X	X	X	X	X	X	X	X	X	X	X	-
08	354133-453	FACE PLATE SCREW	X	X	X	X	X	X	X	X	X	X	X	X	X	X	X	X	X	X	X	X
09	356986-XXX	FACE PLATE COMPLETE (WITH GRILL)	-	-	-	-	-	-	-	-	-	-	-	-	-	-	-	-	-	-	-	-
09	356987-XXX	FACE PLATE COMPLETE (WITHOUT GRILL)	-	-	-	-	-	-	-	-	-	-	-	-	-	-	-	-	-	-	-	-
10	514608	BED (BOTTOM) COVER FASTENING SCREW NUT	X	X	X	X	X	X	X	X	X	X	X	X	X	X	X	X	X	X	X	-
11	356956-451	BED EXTENSION LID	X	X	X	X	X	X	X	X	X	X	X	X	X	X	X	X	X	X	X	-
12	357002	BED EXTENSION SPRING	X	X	X	X	X	X	X	X	X	X	X	X	X	X	X	X	X	X	X	-
13	353559-451	BED CUSHION	X	X	X	X	X	X	X	X	X	X	X	X	X	X	X	X	X	X	X	X
14	357056-451	BED EXTENSION CLOTH PLATE LID LIFTING PIN	X	X	X	X	X	X	X	X	X	X	X	X	X	X	X	X	X	X	X	-
15	357059	BED EXTENSION CLOTH PLATE LID LIFTING PIN SPRING	X	X	X	X	X	X	X	X	X	X	X	X	X	X	X	X	X	X	X	-
16	446417	BED EXTENSION CLOTH PLATE LID LIFTING PIN RETAINING RING	X	X	X	X	X	X	X	X	X	X	X	X	X	X	X	X	X	X	X	-
17	357064	BED EXTENSION CLOTH PLATE CUSHION	X	X	X	X	X	X	X	X	X	X	X	X	X	X	X	X	X	X	X	-
18	357356	UNDER BED COVER (PLASTIC)	-	-	-	-	-	-	-	-	-	-	-	-	-	-	-	-	-	-	-	X
19	113455-003	UNDER BED COVER SCREW	-	-	-	-	-	-	-	-	-	-	-	-	-	-	-	-	-	-	-	X

From the library of Xerox and Xerox Corp

NOTE: PLEASE WHEN NEED THE PART(-----XXX), INDICATE THE MACHINE MODEL WHERE WILL BE USED.

9800 series, 5017 model, CP-17 model, 5028 and 5040 model.
P/N 357669-001

Adopt.

NEEDLE BAR

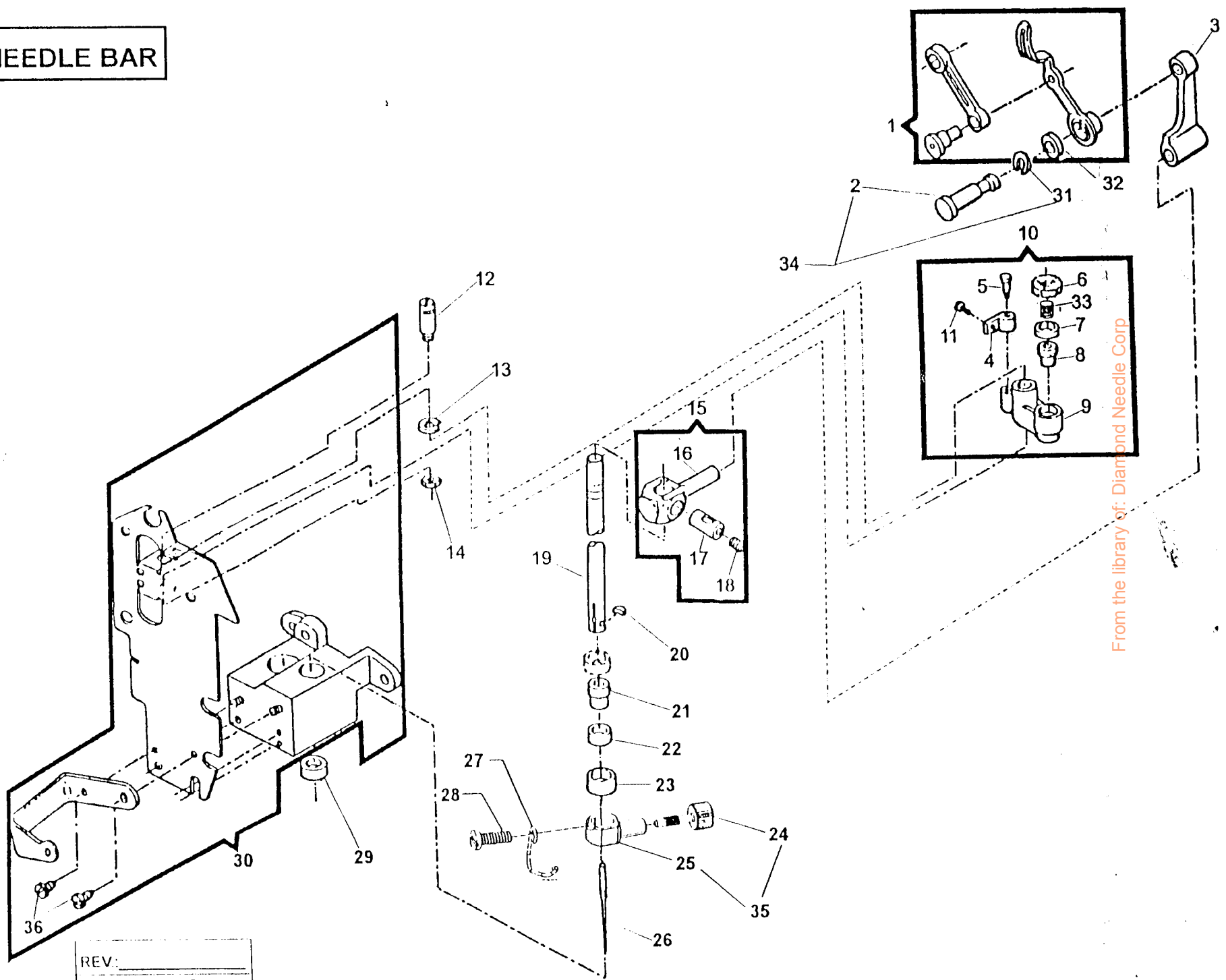

From the library of: Diamond Needle Corp

REV: _____
 DATE: DEC/98

PART LIST
NEEDLE BAR

9 9 9 5 C 9 9 9 9 9 9 5 9 9 9 5 9 9 9
8 8 8 0 P 8 8 8 8 8 8 0 8 8 8 0 8 8 9
0 0 0 1 1 0 0 1 1 1 1 2 1 2 2 4 3 3 3
2 3 5 7 7 6 8 0 2 4 6 8 8 4 8 0 2 6 6

REF. PART NBR

DESCRIPTION

REF. PART NBR	DESCRIPTION	9	9	9	5	C	9	9	9	9	9	9	5	9	9	9	5	9	9	9	5	9	9	9	9	9	9
01 445672	THREAD TAKE-UP LEVER COMPLETE	X	X	X	X	X	X	X	X	X	X	X	X	X	X	X	X	X	X	X	X	X	X	X	X	X	X
02 446260	THREAD TAKE-UP STUD	X	X	X	X	X	X	X	X	X	X	X	X	X	X	X	X	X	X	X	X	X	X	X	X	X	X
03 446357	NEEDLE BAR CONNECTING LINK	X	X	X	X	X	X	X	X	X	X	X	X	X	X	X	X	X	X	X	X	X	X	X	X	X	X
04 446190	NEEDLE BAR DRIVING ARM HINGE BRACKET	X	X	X	X	X	X	X	X	X	X	X	X	X	X	X	X	X	X	X	X	X	X	X	X	X	X
05 37935	NEEDLE BAR DRIVING ARM HINGE BRACKET HINGE PIN	X	X	X	X	X	X	X	X	X	X	X	X	X	X	X	X	X	X	X	X	X	X	X	X	X	X
06 353522-001	NEEDLE BAR BALL BUSHING (UPPER) RETAINING RING	X	X	X	X	X	X	X	X	X	X	X	X	X	X	X	X	X	X	X	X	X	X	X	X	X	X
07 357615	NEEDLE BAR BALL BUSHING (UPPER) SOCKET (LOWER)	X	X	X	X	X	X	X	X	X	X	X	X	X	X	X	X	X	X	X	X	X	X	X	X	X	X
08 446355-001	NEEDLE BAR BALL BUSHING (UPPER)	X	X	X	X	X	X	X	X	X	X	X	X	X	X	X	X	X	X	X	X	X	X	X	X	X	X
09 353521	NEEDLE BAR VIBRATING BRACKET	X	X	X	X	X	X	X	X	X	X	X	X	X	X	X	X	X	X	X	X	X	X	X	X	X	X
10 353520-001	NEEDLE BAR VIBRATING BRACKET COMPLETE	X	X	X	X	X	X	X	X	X	X	X	X	X	X	X	X	X	X	X	X	X	X	X	X	X	X
11 354826-451	NEEDLE BAR DRIVING ARM HINGE BRACKET SCREW	X	X	X	X	X	X	X	X	X	X	X	X	X	X	X	X	X	X	X	X	X	X	X	X	X	X
12 446359	NEEDLE BAR VIBRATING BRACKET HINGE PIN	X	X	X	X	X	X	X	X	X	X	X	X	X	X	X	X	X	X	X	X	X	X	X	X	X	X
13 445721	NEEDLE BAR VIBRATING BRACKET HINGE PIN RETAINING RING	X	X	X	X	X	X	X	X	X	X	X	X	X	X	X	X	X	X	X	X	X	X	X	X	X	X
14 357093-451	NEEDLE BAR VIBRATING BRACKET HINGE PIN NUT	X	X	X	X	X	X	X	X	X	X	X	X	X	X	X	X	X	X	X	X	X	X	X	X	X	X
15 353549-940	NEEDLE BAR CONNECTING STUD WITH HINGE PIN	X	X	X	X	X	X	X	X	X	X	X	X	X	X	X	X	X	X	X	X	X	X	X	X	X	X
16 353549	NEEDLE BAR CONNECTING STUD	X	X	X	X	X	X	X	X	X	X	X	X	X	X	X	X	X	X	X	X	X	X	X	X	X	X
17 37931	NEEDLE BAR CONNECTING STUD HINGE PIN	X	X	X	X	X	X	X	X	X	X	X	X	X	X	X	X	X	X	X	X	X	X	X	X	X	X
18 141916-833	NEEDLE BAR CLAMPING SCREW	X	X	X	X	X	X	X	X	X	X	X	X	X	X	X	X	X	X	X	X	X	X	X	X	X	X
19 445793	NEEDLE BAR	X	X	X	X	X	X	X	X	X	X	X	X	X	X	X	X	X	X	X	X	X	X	X	X	X	X
20 37943	NEEDLE BAR GIB	X	X	X	X	X	X	X	X	X	X	X	X	X	X	X	X	X	X	X	X	X	X	X	X	X	X
21 446355-001	NEEDLE BAR BALL BUSHING (LOWER)	X	X	X	X	X	X	X	X	X	X	X	X	X	X	X	X	X	X	X	X	X	X	X	X	X	X
22 507379	NEEDLE BAR BALL BUSHING (LOWER) SOCKET	X	X	X	X	X	X	X	X	X	X	X	X	X	X	X	X	X	X	X	X	X	X	X	X	X	X
23 446361-001	NEEDLE BAR BALL BUSHING (LOWER) ADJUSTING COLLAR	X	X	X	X	X	X	X	X	X	X	X	X	X	X	X	X	X	X	X	X	X	X	X	X	X	X
24 355248-451	NEEDLE THUMB SCREW	X	X	X	X	X	X	X	X	X	X	X	X	X	X	X	X	X	X	X	X	X	X	X	X	X	X
25 357429	NEEDLE CLAMP BODY	X	X	X	X	X	X	X	X	X	X	X	X	X	X	X	X	X	X	X	X	X	X	X	X	X	X
26 204514-100	NEEDLE 2045 SIZE NBR 14	X	X	X	X	X	X	X	X	X	X	X	X	X	X	X	X	X	X	X	X	X	X	X	X	X	X
26 202014-100	NEEDLE 2020 SIZE NBR 14 (FOR JAPAN ONLY)	X	X	X	X	X	X	X	X	X	X	X	X	X	X	X	X	X	X	X	X	X	X	X	X	X	X
27 357421	NEEDLE CLAMP THREAD GUIDE	X	X	X	X	X	X	X	X	X	X	X	X	X	X	X	X	X	X	X	X	X	X	X	X	X	X
28 141920-455	ND.CLAMP BODY, ND.CLAMP THREAD GUIDE & ND.STOP SCREW	X	X	X	X	X	X	X	X	X	X	X	X	X	X	X	X	X	X	X	X	X	X	X	X	X	X
29 44450	NEEDLE BAR BALL BUSHING (LOWER) SOCKET (UPPER)	X	X	X	X	X	X	X	X	X	X	X	X	X	X	X	X	X	X	X	X	X	X	X	X	X	X
30 357360-000	NEEDLE BAR, PRESSER BAR & VIBR.BKT.HOUSING ASSEMBLY	X	X	X	X	X	X	X	X	X	X	X	X	X	X	X	X	X	X	X	X	X	X	X	X	X	X

From the library of Diamond Needle Corp

9800 series, 5017 model, CP-17 model, 5028 and 5040 model.
P/N 357669-001

Adopt

**PART LIST
NEEDLE BAR**

9 9 9 5 C 9 9 9 9 9 9 5 9 9 9 5 9 9 9
 8 8 8 0 P 8 8 8 8 8 8 0 8 8 8 0 8 8 9
 0 0 0 1 1 0 0 1 1 1 1 2 1 2 2 4 3 3 3
 2 3 5 7 7 6 8 0 2 4 6 8 8 4 8 0 2 6 6

REF. PART NBR

DESCRIPTION

31	445486	THREAD TAKE-UP STUD RETAINING RING
32	543531	THREAD TAKE-UP STUD THRUST WASHER
33	357616	NEEDLE BAR BALL BUSHING (UPPER) SOCKET SPRING
34	446261	THREAD TAKE-UP STUD WITH RETAINING RING
35	357430	NEEDLE CLAMP BODY WITH SCREW
36	113480-451	ND.BAR, PRESSER BAR & VIBR.BKT.HOUS.PLATE MTG.SCREW

X X X X X X X X X X X X X X X X X X X
 X X X X X X X X X X X X X X X X X X X
 X X X X X X X X X X X X X X X X X X X
 X X X X X X X X X X X X X X X X X X X
 X X X X X X X X X X X X X X X X X X X
 X X X X X X X X X X X X X X X X X X X

<u>REF.</u>	<u>EW P/N</u>	<u>IN PLACE OF</u>	<u>IMPLEMENTATION DATE</u>
14	357093-451	353402-451	05/31/94
25	357429	353629	08/26/96
27	357421	353629	0826/96
28	141920-453	141803-451	0826/96
28	41920-455	141920-453	21/10/97
35	57430	353631	08/26/96
30	357360-000	356599	08/26/98
33	357616	353424	27/10/98

From the library of: Diamond Needle Corp.

PRESSER BAR

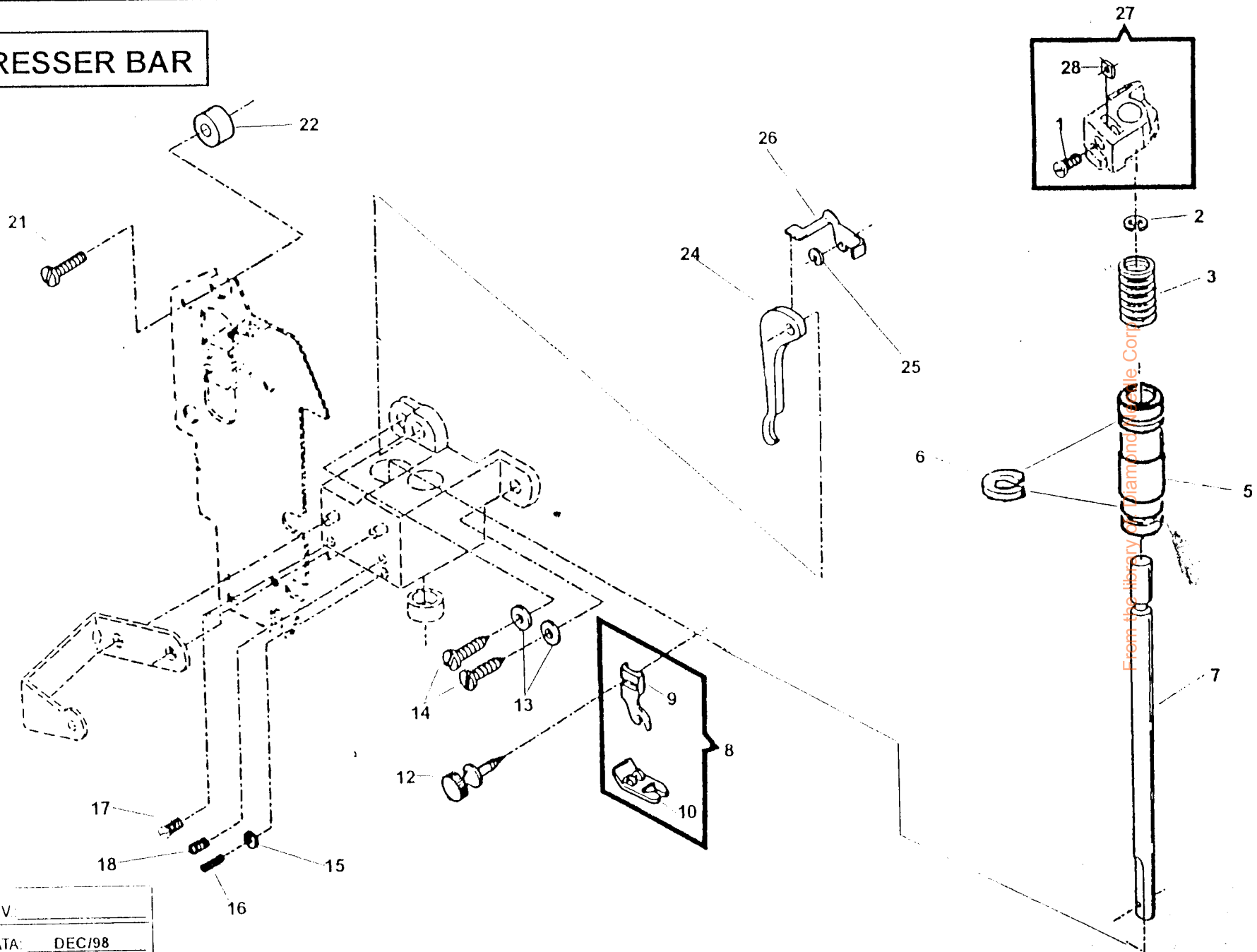

REV _____
DATA: DEC/98

From the library of <http://www.iamandible.com>

**PART LIST
PRESSER BAR**

9 9 9 5 C 9 9 9 9 9 9 5 9 9 5 9 9 9
 8 8 8 0 P 8 8 8 8 8 8 0 8 8 8 0 8 8 9
 0 0 0 1 1 0 0 1 1 1 1 2 1 2 2 4 3 3 3
 2 3 5 7 7 6 8 0 2 4 6 8 8 4 8 0 2 6 6

REF.	PART NBR	DESCRIPTION
01	355279-451	PRESSER BAR GUIDE BRACKET SET SCREW
02	353215	PRESSER BAR SPRING RETAINING RING (UPPER)
03	357362	PRESSER BAR SPRING
05	445947-001	PRESSER BAR BUSHING
06	357604	PRESSER BAR BUSHING LOCATING RING
07	357602	PRESSER BAR
08	446372	PRESSER FOOT (SNAP-ON) COMPLETE FOR ZIG-ZAG SEWING
09	155964	PRESSER FOOT SHANK (SNAP-ON)
10	446371	PRESSER FOOT PLATE (SNAP-ON) FOR ZIG-ZAG SEWING
11	357363	PRESSER BAR GUIDE BACKET ASSEMBLY
12	354135-452	PRESSER FOOT THUMB SCREW
13	353375-451	NEEDLE BAR, PRESSER BAR & VIBRATING BRACKET HOUSING MOUNTING SCREW (LOWER) WASHER
14	113434-451	NEEDLE BAR, PRESSER BAR & VIBRATING BRACKET HOUSING MOUTING SCREW (LOWER)
15	54591-451	NEEDLE BAR OVER THROW SET SCREW NUT
16	354993-451	NEEDLE BAR OVER THROW SET SCREW
17	354906-451	PRESSER BAR BUSHING SET SCREW
18	141938-833	NEEDLE BAR BALL BUSHING (LOWER) ADJUSTING COLLAR SET SCREW
21	113455-009	NEEDLE BAR & PRESSER BAR VIBRATING BRACKET HOUSING MOUNTING SCREW (UPPER)
22	531627	NEEDLE BAR, PRESSER BAR & VIBRATING BRACKET HOUSING HOUSING MOUNTING BUSHING
24	356170-451	PRESSER BAR LIFTER
25	445486	TENSION RELEASING LEVER RETAINING RING
26	445925	TENSION RELEASING LEVER
27	353367-451	PRESSER BAR GUIDE BRACKET NUT

X	X	X	X	X	X	X	X	X	X	X	X	X	X	X	X	X	X	X	X
X	X	X	X	X	X	X	X	X	X	X	X	X	X	X	X	X	X	X	X
X	X	X	X	X	X	X	X	X	X	X	X	X	X	X	X	X	X	X	X
X	X	X	X	X	X	X	X	X	X	X	X	X	X	X	X	X	X	X	X
X	X	X	X	X	X	X	X	X	X	X	X	X	X	X	X	X	X	X	X
X	X	X	X	X	X	X	X	X	X	X	X	X	X	X	X	X	X	X	X
X	X	X	X	X	X	X	X	X	X	X	X	X	X	X	X	X	X	X	X
X	X	X	X	X	X	X	X	X	X	X	X	X	X	X	X	X	X	X	X
X	X	X	X	X	X	X	X	X	X	X	X	X	X	X	X	X	X	X	X
X	X	X	X	X	X	X	X	X	X	X	X	X	X	X	X	X	X	X	X
X	X	X	X	X	X	X	X	X	X	X	X	X	X	X	X	X	X	X	X
X	X	X	X	X	X	X	X	X	X	X	X	X	X	X	X	X	X	X	X
X	X	X	X	X	X	X	X	X	X	X	X	X	X	X	X	X	X	X	X
X	X	X	X	X	X	X	X	X	X	X	X	X	X	X	X	X	X	X	X
X	X	X	X	X	X	X	X	X	X	X	X	X	X	X	X	X	X	X	X
X	X	X	X	X	X	X	X	X	X	X	X	X	X	X	X	X	X	X	X
X	X	X	X	X	X	X	X	X	X	X	X	X	X	X	X	X	X	X	X
X	X	X	X	X	X	X	X	X	X	X	X	X	X	X	X	X	X	X	X
X	X	X	X	X	X	X	X	X	X	X	X	X	X	X	X	X	X	X	X
X	X	X	X	X	X	X	X	X	X	X	X	X	X	X	X	X	X	X	X

Buy the Library of Diamond Needle Co.

REF.	NEW P/N	IN PLACE OF	IMPLEMENTATION DATE
04	357604	353255	03/10/97
06	357604	353255	03/10/97
23	-----	446354-451	03/10/97
24	356170-451	446356	08/02/95
03	357362	353214	01/26/98
07	357602	314638	01/26/98
11	357363	353212	01/26/98

9800 series, 5017 model, CP-17 model, 5028 and 5040 model
 P/N 357669-001

ARM SHAFT DRIVE

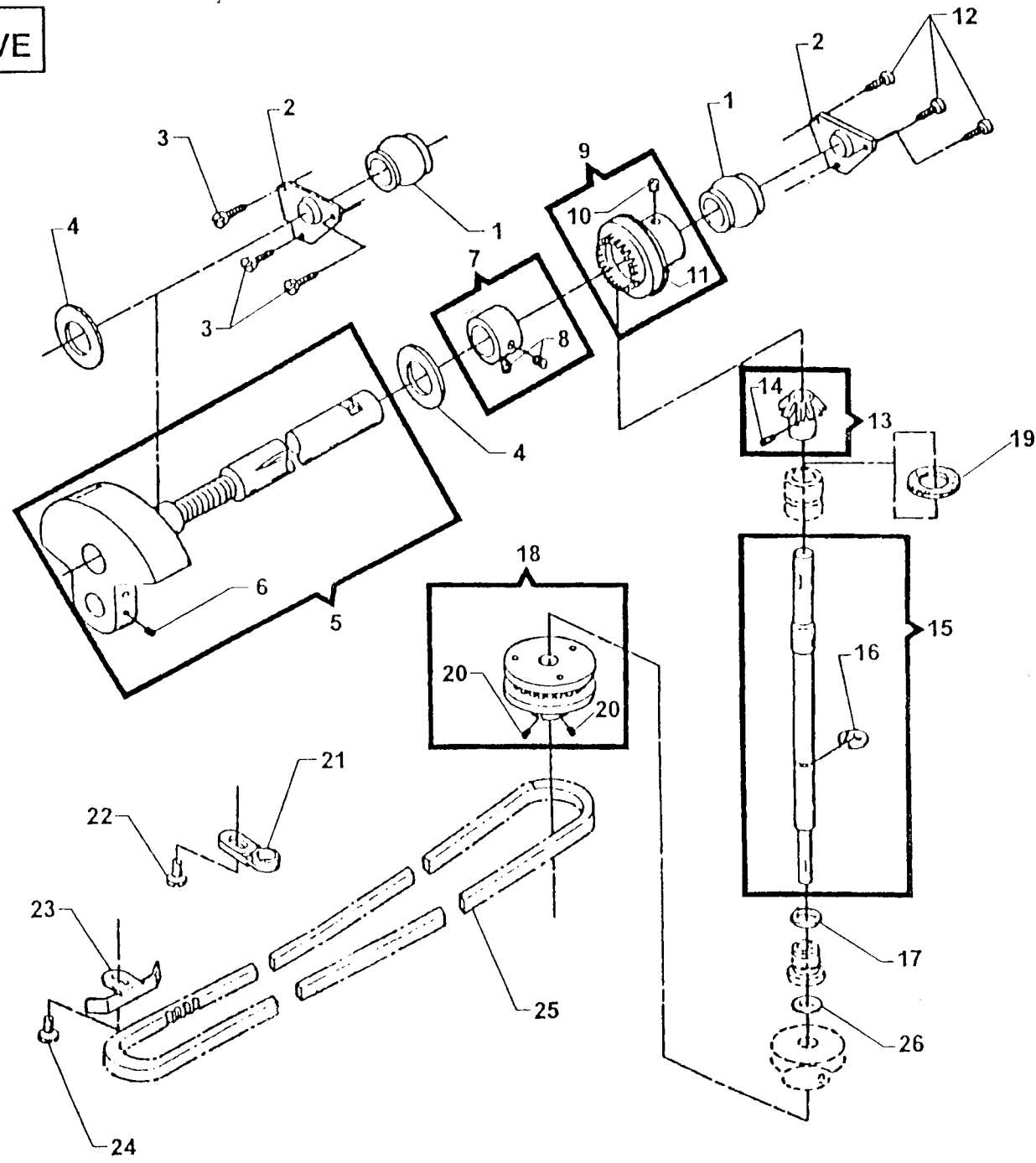

From the library of: Diamond Needle Corp

REV: _____
DATE: DEC/98

PART LIST
ARM SHAFT DRIVE

9 9 9 5 C 9 9 9 9 9 9 5 9 9 9 5 9 9 9
 8 8 8 0 P 8 8 8 8 8 8 0 8 8 8 0 8 8 9
 0 0 0 1 1 0 0 1 1 1 1 2 1 2 2 4 3 3 3
 2 3 5 7 7 6 8 0 2 4 6 8 8 4 8 0 2 6 6

REF. PART NBR

DESCRIPTION

01	446384	ARM SHAFT BUSHING (FRONT)	X	X	X	X	X	X	X	X	X	X	X	X	X	X	X	X	X
02	446385	ARM SHAFT BUSHING (FRONT) RETAINING BRACKET	X	X	X	X	X	X	X	X	X	X	X	X	X	X	X	X	X
03	113455-001	ARM SHAFT BUSHING (FRONT) RETAINING BRACKET SCREW	X	X	X	X	X	X	X	X	X	X	X	X	X	X	X	X	X
04	319764	ARM SHAFT (HORIZONTAL)RETAINING COLLAR WASHER	X	X	X	X	X	X	X	X	X	X	X	X	X	X	X	X	X
05	531684	ARM SHAFT COMPLETE	X	X	X	X	X	X	X	X	X	X	X	X	X	X	X	X	X
06	354105-833	THREAD TAKE-UP SET SCREW	X	X	X	X	X	X	X	X	X	X	X	X	X	X	X	X	X
07	353580	ARM SHAFT (HORIZONTAL) RETAINING COLLAR	X	X	X	X	X	X	X	X	X	X	X	X	X	X	X	X	X
08	113500-451	ARM SHAFT (HORIZONTAL) RETAINING COLLAR SET SCREW	X	X	X	X	X	X	X	X	X	X	X	X	X	X	X	X	X
09	353272	ARM SHAFT (HORIZONTAL) BEVEL GEAR & FEED LIFTING (ECCENTRIC) COMPLETE	X	X	X	X	X	X	X	X	X	X	X	X	X	X	X	X	X
10	354813-451	ARM SHAFT (HORIZONTAL) BEVEL GEAR & FEED LIFTING ECCENTRIC SET SCREW	X	X	X	X	X	X	X	X	X	X	X	X	X	X	X	X	X
11	353413	ARM SHAFT (HORIZONTAL) BEVEL GEAR & FEED LIFTING ECCENTRIC WASHER (PLASTIC)	X	X	X	X	X	X	X	X	X	X	X	X	X	X	X	X	X
12	113455-001	ARM SHAFT BUSHING (REAR) RETAINING BRACKET SCREW	X	X	X	X	X	X	X	X	X	X	X	X	X	X	X	X	X
13	353273-002	ARM SHAFT (UPRIGHT) BEVEL GEAR (PLASTIC)	X	X	X	X	X	X	X	X	X	X	X	X	X	X	X	X	X
14	354105-833	ARM SHAFT (UPRIGHT) BEVEL GEAR SET SCREW	X	X	X	X	X	X	X	X	X	X	X	X	X	X	X	X	X
15	179952-002	ARM SHAFT (UPRIGHT) ASSEMBLY	X	X	X	X	X	X	X	X	X	X	X	X	X	X	X	X	X
16	353215	ARM SHAFT (UPRIGHT) RETAINING RING	X	X	X	X	X	X	X	X	X	X	X	X	X	X	X	X	X
17	353394	ARM SHAFT (UPRIGHT) RETAINING RING WASHER	X	X	X	X	X	X	X	X	X	X	X	X	X	X	X	X	X
18	353438-001	ARM SHAFT (UPRIGHT) BELT DRIVE PULLEY ASSEMBLY COMPLETE	X	X	X	X	X	X	X	X	X	X	X	X	X	X	X	X	X
19	356819	ARM SHAFT (UPRIGHT) FEET WASHER	X	X	X	X	X	X	X	X	X	X	X	X	X	X	X	X	X
20	354906-451	ARM SHAFT (UPRIGHT) BELT DRIVE PULLEY RETAINING COLLAR SET SCREW	X	X	X	X	X	X	X	X	X	X	X	X	X	X	X	X	X
21	357461	ROTATING HOOK DRIVE BELT TENSION ADJUSTER	X	X	X	X	X	X	X	X	X	X	X	X	X	X	X	X	X
22	113453-003	ROTATING HOOK DRIVE BELT TENSIONER SCREW	X	X	X	X	X	X	X	X	X	X	X	X	X	X	X	X	X
23	446376	BELT RETAINER (LEFT)	X	X	X	X	X	X	X	X	X	X	X	X	X	X	X	X	X
24	113455-001	BELT RETAINER (LEFT) SCREW	X	X	X	X	X	X	X	X	X	X	X	X	X	X	X	X	X
25	446237	BELT (ROTATING HOOK DRIVE)	X	X	X	X	X	X	X	X	X	X	X	X	X	X	X	X	X
26	319826	ARM SHAFT (UPRIGHT) BELT DRIVE PULLEY WASHER	X	X	X	X	X	X	X	X	X	X	X	X	X	X	X	X	X

From the library of: Diamond Needle Corp

9800 series, 5017 model, CP-17 model, 5028 and 5040 model.
 P/N 357669-001

Adopt.

HAND WHEEL

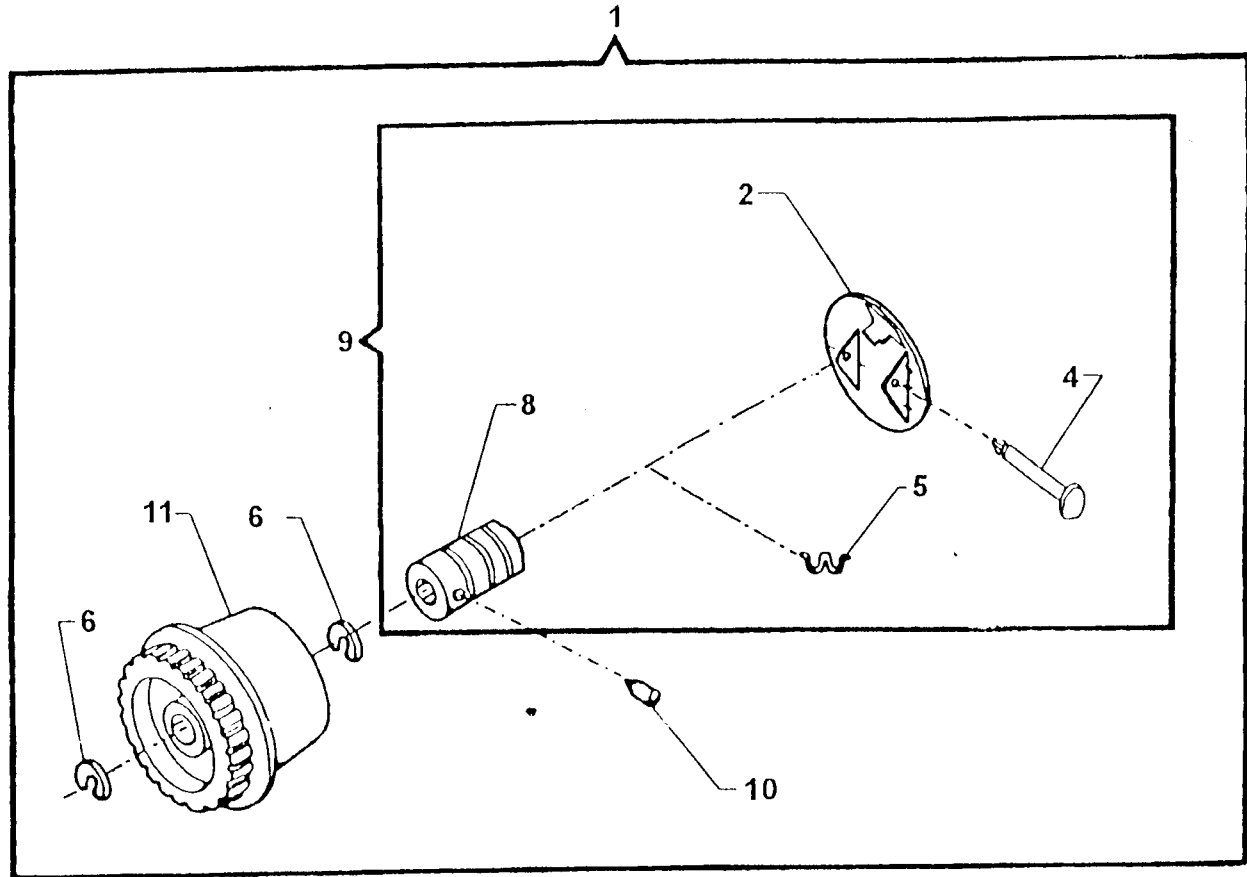

From the library of: Diamond Needle Corp

REV: _____
DATA: DEC/98

**PART LIST
HAND WHEEL**

9 9 9 5 C 9 9 9 9 9 9 5 9 9 9 5 9 9 9
 8 8 8 0 P 8 8 8 8 8 8 0 8 8 8 0 8 8 9
 0 0 0 1 1 0 0 1 1 1 1 2 1 2 2 4 3 3 3
 2 3 5 7 7 6 8 0 2 4 6 8 8 4 8 0 2 6 6

REF. PART NBR

DESCRIPTION

01	357009-451	HAND WHEEL (ELECTRIC) COMPLETE	X	X	X	X	X	X	X	X	X	X	X	X	X	X	X	X	X	X
02	357367-901	HAND WHEEL DISENGAGING CLUTCH ENGAGING PLATE COVER	X	X	X	X	X	X	X	X	X	X	X	X	X	X	X	X	X	X
04	357364	HAND WHEEL DISENGAGING CLUTCH ENGAGING PLATE HINGE PIN	X	X	X	X	X	X	X	X	X	X	X	X	X	X	X	X	X	X
05	357365	HAND WHEEL DISENGAGING CLUTCH ACTUATING SPRING	X	X	X	X	X	X	X	X	X	X	X	X	X	X	X	X	X	X
06	446387	HAND WHEEL RETAINING RING (TREADLE/ELECTRIC)	X	X	X	X	X	X	X	X	X	X	X	X	X	X	X	X	X	X
08	357359	HAND WHEEL DISENGAGING CLUTCH BUSHING	X	X	X	X	X	X	X	X	X	X	X	X	X	X	X	X	X	X
09	357368-452	HAND WHEEL DISENGAGING CLUTCH BUSHING COMPLETE	X	X	X	X	X	X	X	X	X	X	X	X	X	X	X	X	X	X
10	354813-451	HAND WHEEL DISENGAGING CLUTCH BUSHING SCREW	X	X	X	X	X	X	X	X	X	X	X	X	X	X	X	X	X	X
11	356958-451	HAND WHEEL (PLASTIC)	X	X	X	X	X	X	X	X	X	X	X	X	X	X	X	X	X	X

From the library of: Diamond Needle Corp.

<u>REF.</u>	<u>NEW P/N</u>	<u>IN PLACE OF</u>	<u>IMPLEMENTATION DATE</u>
02	357367-901	446297-904	02/05/96
03	-----	445721	02/05/96
04	357364	319560	02/05/96
05	357365	531628	02/05/96
07	-----	319566	02/05/96
08	357359	446390	02/05/96
09	357368-452	446343-453	02/05/96

9800 series, 5017 model, CP-17 model, 5028 and 5040 model.
 P/N 357669-001

Adopt.

TENSION MECHANISM

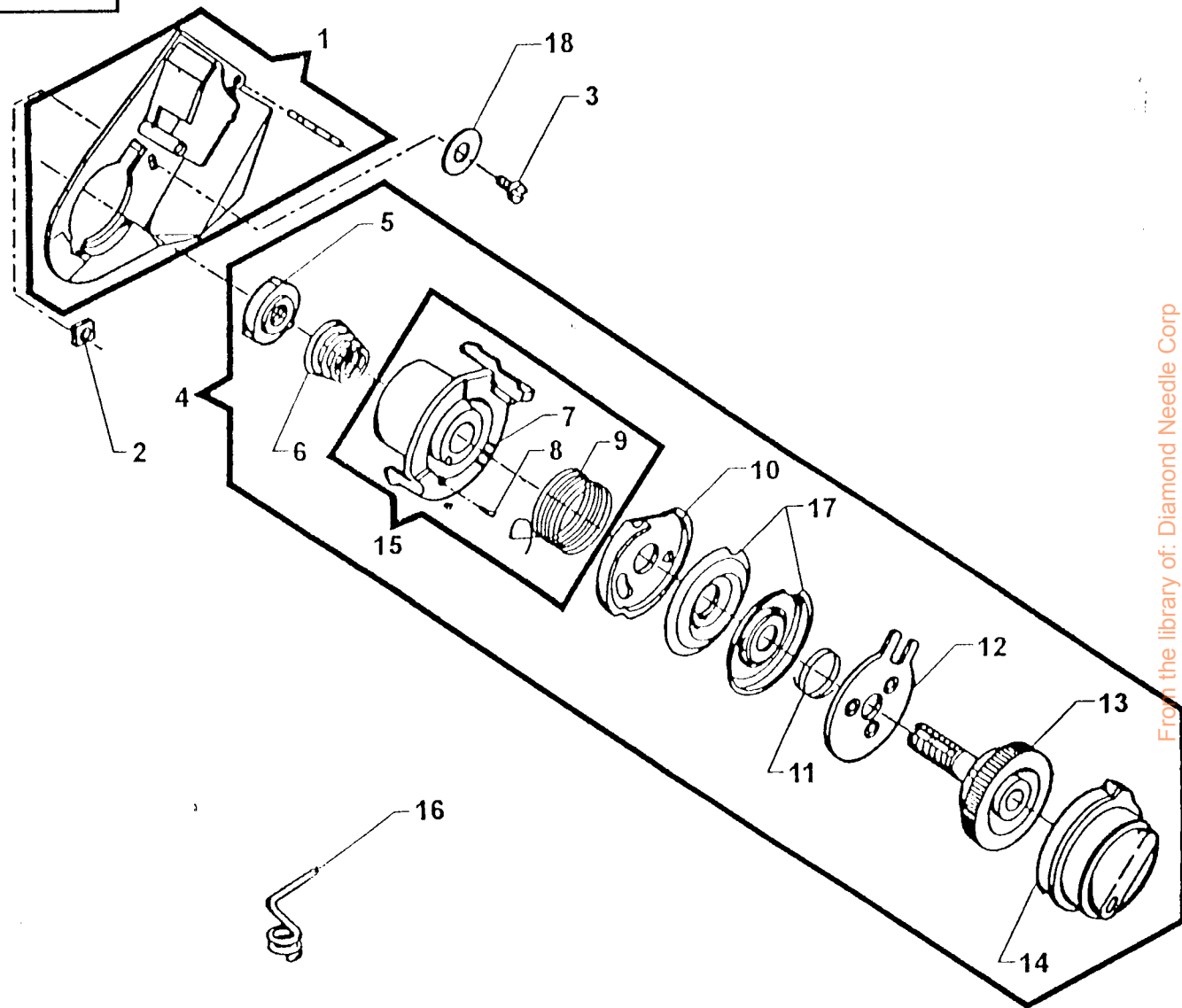

From the library of: Diamond Needle Corp

REV: _____
DATA: DEC/98

**PART LIST
TENSION MECHANISM**

9 9 9 5 C 9 9 9 9 9 9 5 9 9 9 5 9 9 9
 8 8 8 0 P 8 8 8 8 8 8 0 8 8 8 0 8 8 9
 0 0 0 1 1 0 0 1 1 1 1 2 1 2 2 4 3 3 3
 2 3 5 7 7 6 8 0 2 4 6 8 8 4 8 0 2 6 6

REF. PART NBR

DESCRIPTION

01	356040-452	TENSION MECHANISM SHROUDER ASSEMBLY
02	514698-451	TENSION MECHANISM SHROUDER SCREW NUT
03	141808-457	TENSION MECHANISM SHROUDER SCREW
04	356088-XXX	TENSION MECHANISM ASSEMBLY
05	356095	TENSION STUD NUT
06	356096	TENSION SPRING
07	356089	TENSION MECHANISM SUPPORT
08	356246-900	TENSION MECHANISM SUPPORT PIN
09	356097	THREAD TAKE-UP SPRING
10	356091	THREAD TAKE-UP SPRING THREAD GUARD
11	356216	TENSION DISC PRESSURE PLATE SPRING
12	356177	TENSION DISC PRESSURE PLATE
13	356092-451	TENSION INDICATOR WITH STUD
14	356090-XXX	TENSION INDICATOR DIAL
15	356245	TENSION MECHANISM SUPORT ASSEMBLY
16	445784	THREAD GUIDE (LOWER)
17	356094	TENSION DISC
18	356443	TENSION MECHANISM SHROUDER WASHER

X	X	X	X	X	X	X	X	X	X	X	X	X	X	X	X	X	X	X	X
X	X	X	X	X	X	X	X	X	X	X	X	X	X	X	X	X	X	X	X
X	X	X	X	X	X	X	X	X	X	X	X	X	X	X	X	X	X	X	X
-	-	-	-	-	-	-	-	-	-	-	-	-	-	-	-	-	-	-	-
X	X	X	X	X	X	X	X	X	X	X	X	X	X	X	X	X	X	X	X
X	X	X	X	X	X	X	X	X	X	X	X	X	X	X	X	X	X	X	X
X	X	X	X	X	X	X	X	X	X	X	X	X	X	X	X	X	X	X	X
X	X	X	X	X	X	X	X	X	X	X	X	X	X	X	X	X	X	X	X
X	X	X	X	X	X	X	X	X	X	X	X	X	X	X	X	X	X	X	X
X	X	X	X	X	X	X	X	X	X	X	X	X	X	X	X	X	X	X	X
X	X	X	X	X	X	X	X	X	X	X	X	X	X	X	X	X	X	X	X
X	X	X	X	X	X	X	X	X	X	X	X	X	X	X	X	X	X	X	X
X	X	X	X	X	X	X	X	X	X	X	X	X	X	X	X	X	X	X	X
X	X	X	X	X	X	X	X	X	X	X	X	X	X	X	X	X	X	X	X
X	X	X	X	X	X	X	X	X	X	X	X	X	X	X	X	X	X	X	X

From the library of Diamond Needle Corp

NOTE: PLEASE WHEN NEED THE PART NUMBER(-----XXX), INDICATE THE MACHINE MODEL WHERE WILL BE USED..

9800 series, 5017 model, CP-17 model, 5028 and 5040 model.
 PIN 357669-001

Adopt.

HOOK SYSTEM

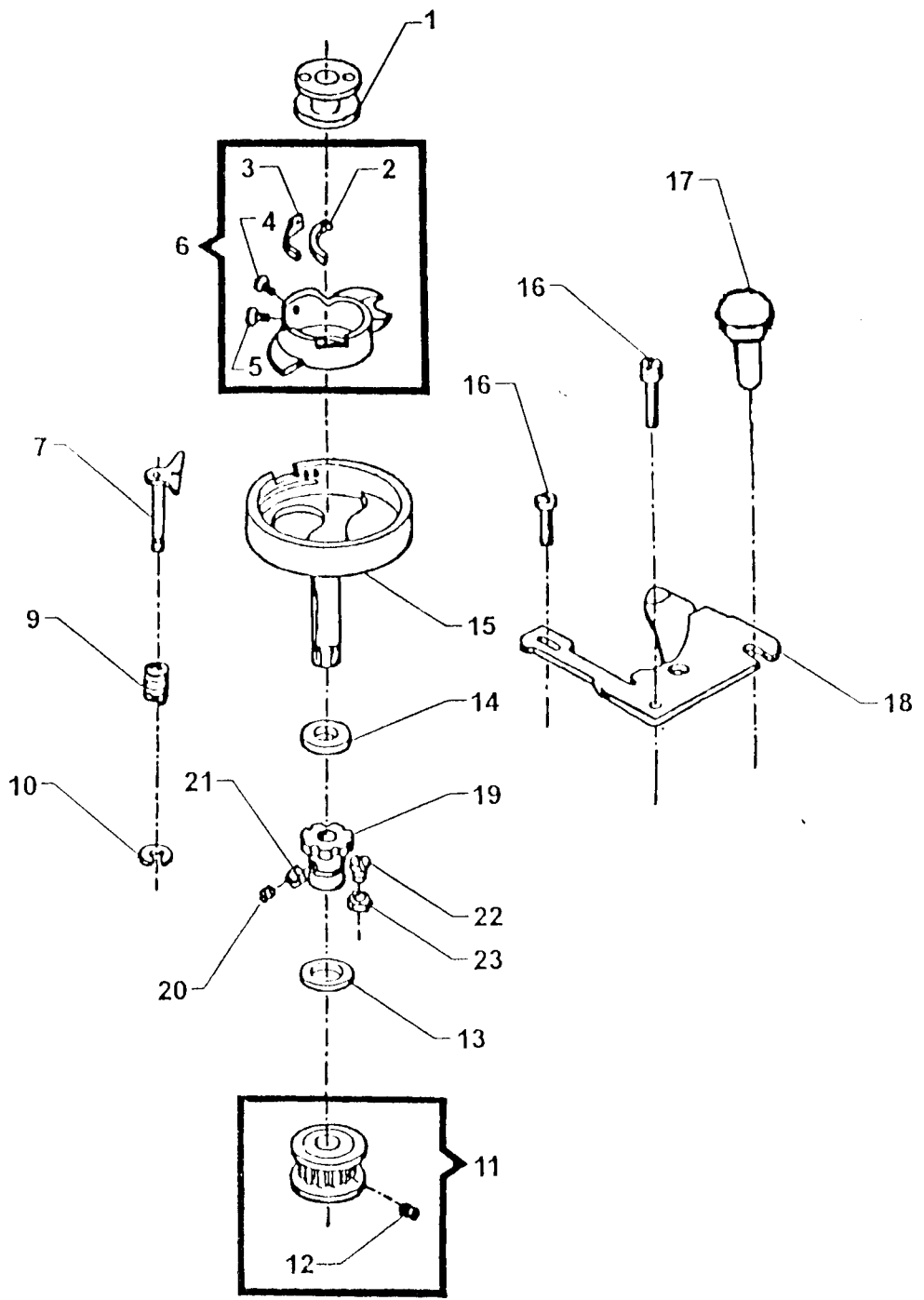

From the library of: Diamond Needle Corp

REV: _____
DATA: DEC/98

**PART LIST
HOOK SYSTEM**

9 9 9 5 C 9 9 9 9 9 9 5 9 9 5 9 9
 8 8 8 0 P 8 8 8 8 8 8 0 8 8 8 8 8 8 9
 0 0 0 1 1 0 0 1 1 1 1 2 1 2 2 4 3 3 3
 2 3 5 7 7 6 8 0 2 4 6 8 8 4 8 0 2 6 6

REF. PART NBR	DESCRIPTION																			
01	172336	ROTATING HOOK BOBBIN (PLASTIC)	X	X	X	X	X	X	X	X	X	X	X	X	X	X	X	X	X	X
02	356490-451	ROTATING HOOK BOBBIN CASE TENSION SPRING SEGMENT	X	X	X	X	X	X	X	X	X	X	X	X	X	X	X	X	X	X
03	314715	ROTATING HOOK BOBBIN CASE TENSION SPRING	X	X	X	X	X	X	X	X	X	X	X	X	X	X	X	X	X	X
04	355254-451	ROTATING HOOK BOBBIN CASE TENSION REGULATING SCREW	X	X	X	X	X	X	X	X	X	X	X	X	X	X	X	X	X	X
05	139975-452	ROTATING HOOK BOBBIN CASE TENSION SPRING SEG. SCREW	X	X	X	X	X	X	X	X	X	X	X	X	X	X	X	X	X	X
06	421325	ROTATING HOOK BOBBIN CASE	X	X	X	X	X	X	X	X	X	X	X	X	X	X	X	X	X	X
07	353511	ROTATING HOOK BOBBIN CASE RETAINING PLATE ASSEMBLY	X	X	X	X	X	X	X	X	X	X	X	X	X	X	X	X	X	X
09	44892	ROTATING HOOK BOBBIN CASE RETAINING PLATE STUD SPRING	X	X	X	X	X	X	X	X	X	X	X	X	X	X	X	X	X	X
10	446417	ROTATING HOOK BOBBIN CASE RETAINING PLATE RETAINING RING	X	X	X	X	X	X	X	X	X	X	X	X	X	X	X	X	X	X
11	446235	ROTATING HOOK BELT DRIVE PULLEY	X	X	X	X	X	X	X	X	X	X	X	X	X	X	X	X	X	X
12	141803-451	ROTATING HOOK BELT DRIVE PULLEY SCREW	X	X	X	X	X	X	X	X	X	X	X	X	X	X	X	X	X	X
13	382861-906	ROTATING HOOK BELT DRIVE PULLEY WASHER	X	X	X	X	X	X	X	X	X	X	X	X	X	X	X	X	X	X
14	353453	ROTATING HOOK WEAR WASHER	X	X	X	X	X	X	X	X	X	X	X	X	X	X	X	X	X	X
15	353366	ROTATING HOOK COMPLETE	X	X	X	X	X	X	X	X	X	X	X	X	X	X	X	X	X	X
15	SK-4366	ROTATING HOOK COMPLETE (FOR JAPAN)	X	X	X	X	X	X	X	X	X	X	X	X	X	X	X	X	X	X
16	354917-451	ROTATING HOOK BOBBIN CASE POSITION PLATE SCREW	X	X	X	X	X	X	X	X	X	X	X	X	X	X	X	X	X	X
17	357349-451	ROTATING HOOK BOBBIN CASE RETAINING PLATE (ADJUSTABLE & POSITION PLATE)STUD	X	X	X	X	X	X	X	X	X	X	X	X	X	X	X	X	X	X
18	44873-001	ROTATING HOOK BOBBIN CASE POSITION PLATE	X	X	X	X	X	X	X	X	X	X	X	X	X	X	X	X	X	X
19	353410-900	ROTATING HOOK BUSHING	X	X	X	X	X	X	X	X	X	X	X	X	X	X	X	X	X	X
20	141938-833	ROTATING HOOK BUSHING SET SCREW	X	X	X	X	X	X	X	X	X	X	X	X	X	X	X	X	X	X
21	353367-451	ROTATING HOOK BUSHING SET SCREW NUT	X	X	X	X	X	X	X	X	X	X	X	X	X	X	X	X	X	X
22	141844-451	ROTATING HOOK BUSHING ADJUSTING SCREW	X	X	X	X	X	X	X	X	X	X	X	X	X	X	X	X	X	X
23	618638-005	ROTATING HOOK BUSHING ADJUSTING SCREW NUT	X	X	X	X	X	X	X	X	X	X	X	X	X	X	X	X	X	X

From the library of: Diamond Needle Corp.

REF.	NEW P/N	IN PLACE OF	IMPLEMENTATION DATE
04	355254-451	354183-452	08/15/97
10	446417	353509	06/29/93
16	354917-451	113430-451	07/25/95
17	357349-451	113430-451	07/25/95
23	618638-005	44502-900	08/25/97

**9800 series, 5017 model, CP-17 model, 5028 and 5040 model.
P/N 357669-001**

Adopt.

BIGHT AMPLITUDE

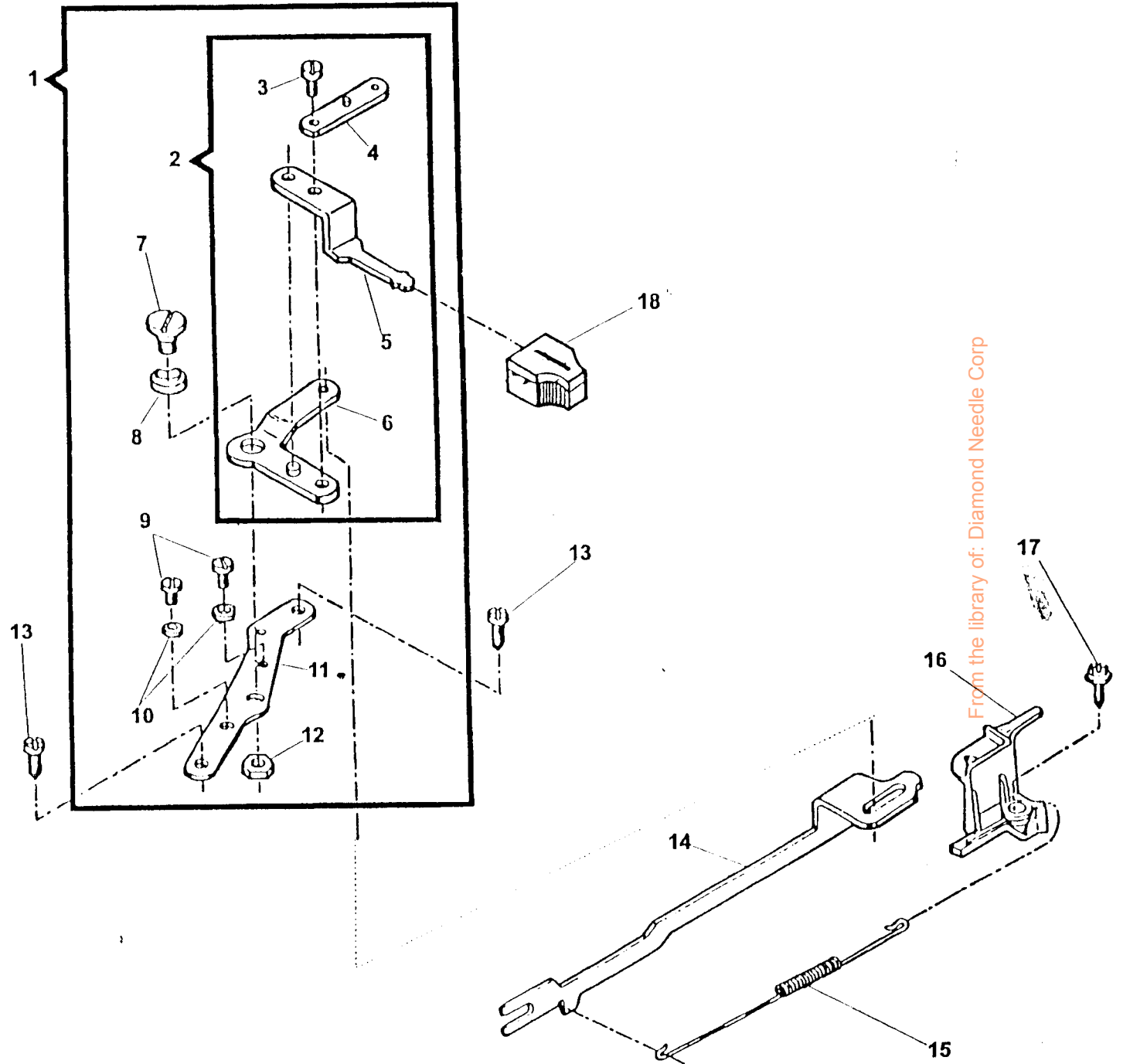

From the library of: Diamond Needle Corp

REV: _____
DATA: DEC/98

**PART LIST
BIGHT AMPLITUDE**

9 9 9 5 C 9 9 9 9 9 5 9 9 9 5 9 9 9
 8 8 8 0 P 8 8 8 8 8 8 0 8 8 8 0 8 8 9
 0 0 0 1 1 0 0 1 1 1 1 2 1 2 2 4 3 3 3
 2 3 5 7 7 6 8 0 2 4 6 8 8 4 8 0 2 6 6

REF. PART NBR

DESCRIPTION

REF. PART NBR	DESCRIPTION	2	3	5	7	7	6	8	0	2	4	6	8	8	4	8	0	2	6	6
01 179893	BIGHT AMPLITUDE CONTROL LEVER MOUNTING BRACKET COMPLETE	-	-	X	X	X	X	X	X	X	X	X	X	X	X	X	X	X	X	X
01 446396	BIGHT AMPLITUDE CONTROL LEVER MOUNTING BRACKET COMPLETE	X	X	-	-	-	-	-	-	-	-	-	-	-	-	-	-	-	-	-
02 446342	BIGHT AMPLITUDE CONTROL LEVER SUB-ASSEMBLY	-	-	X	X	X	X	X	X	X	X	X	X	X	X	X	X	X	X	X
02 446395	BIGHT AMPLITUDE CONTROL LEVER SUB-ASSEMBLY	X	X	-	-	-	-	-	-	-	-	-	-	-	-	-	-	-	-	-
03 139866-451	BIGHT AMPLITUDE CONTROL LEVER SCREW	-	-	X	X	X	X	X	X	X	X	X	X	X	X	X	X	X	X	X
03 141913-451	BIGHT AMPLITUDE CONTROL LEVER SCREW	X	X	-	-	-	-	-	-	-	-	-	-	-	-	-	-	-	-	-
04 44556	BUTTONHOLER BIGHT CONTROL CAM FOLLOWER LEVER LINK (LEFT)	-	-	X	X	X	X	X	X	X	X	X	X	X	X	X	X	X	X	X
05 446394	BIGHT AMPLITUDE CONTROL LEVER	X	X	X	X	X	X	X	X	X	X	X	X	X	X	X	X	X	X	X
06 37246	BIGHT AMPLITUDE CONTROL LEVER LINK	X	X	X	X	X	X	X	X	X	X	X	X	X	X	X	X	X	X	X
07 354825-451	BIGHT AMPLITUDE CONTROL LEVER LINK HINGE SCREW	X	X	X	X	X	X	X	X	X	X	X	X	X	X	X	X	X	X	X
08 49204	BIGHT AMPLITUDE CONTROL LEVER LINK HINGE SCREW FRICTION WASHER	X	X	X	X	X	X	X	X	X	X	X	X	X	X	X	X	X	X	X
09 141913-451	BIGHT AMPLITUDE CONTROL LEVER LINK STOP SCREW	X	X	X	X	X	X	X	X	X	X	X	X	X	X	X	X	X	X	X
10 446904	BIGHT AMPLITUDE CONTROL LEVER LINK STOP	X	X	X	X	X	X	X	X	X	X	X	X	X	X	X	X	X	X	X
11 531793	BIGHT AMPLITUDE CONTROL LEVER MOUNTING BRACKET	X	X	X	X	X	X	X	X	X	X	X	X	X	X	X	X	X	X	X
12 54591-451	BIGHT AMPLITUDE CONTROL LEVER LINK HINGE SCREW NUT	X	X	X	X	X	X	X	X	X	X	X	X	X	X	X	X	X	X	X
13 113455-001	BIGHT AMPLITUDE CONTROL LEVER MOUNTING BRACKET SCREW	X	X	X	X	X	X	X	X	X	X	X	X	X	X	X	X	X	X	X
14 37933-002	NEEDLE BAR DRIVING ARM	X	X	X	X	X	X	X	X	X	X	X	X	X	X	X	X	X	X	X
15 37942	NEEDLE BAR DRIVING ARM TENSION SPRING	X	X	X	X	X	X	X	X	X	X	X	X	X	X	X	X	X	X	X
16 445780	LIGHT LEAD SHIELD & NEEDLE BAR DRIVING ARM TENSION SPRING MOUNTING PLATE	X	X	X	X	X	X	X	X	X	X	X	X	X	X	X	X	X	X	X
17 113455-001	LIGHT LEAD SHIELD & NEEDLE BAR DRIVING ARM TENSION SPRING MOUNTING PLATE SCREW	X	X	X	X	X	X	X	X	X	X	X	X	X	X	X	X	X	X	X
18 356961-451	BIGHT AMPLITUDE CONTROL LEVER KNOB (SNOW WHITE)	X	X	X	X	X	X	X	X	X	X	X	X	X	X	X	X	X	X	X

From the library of: Diagnostics, Inc. Corp.

NEEDLE POSITION

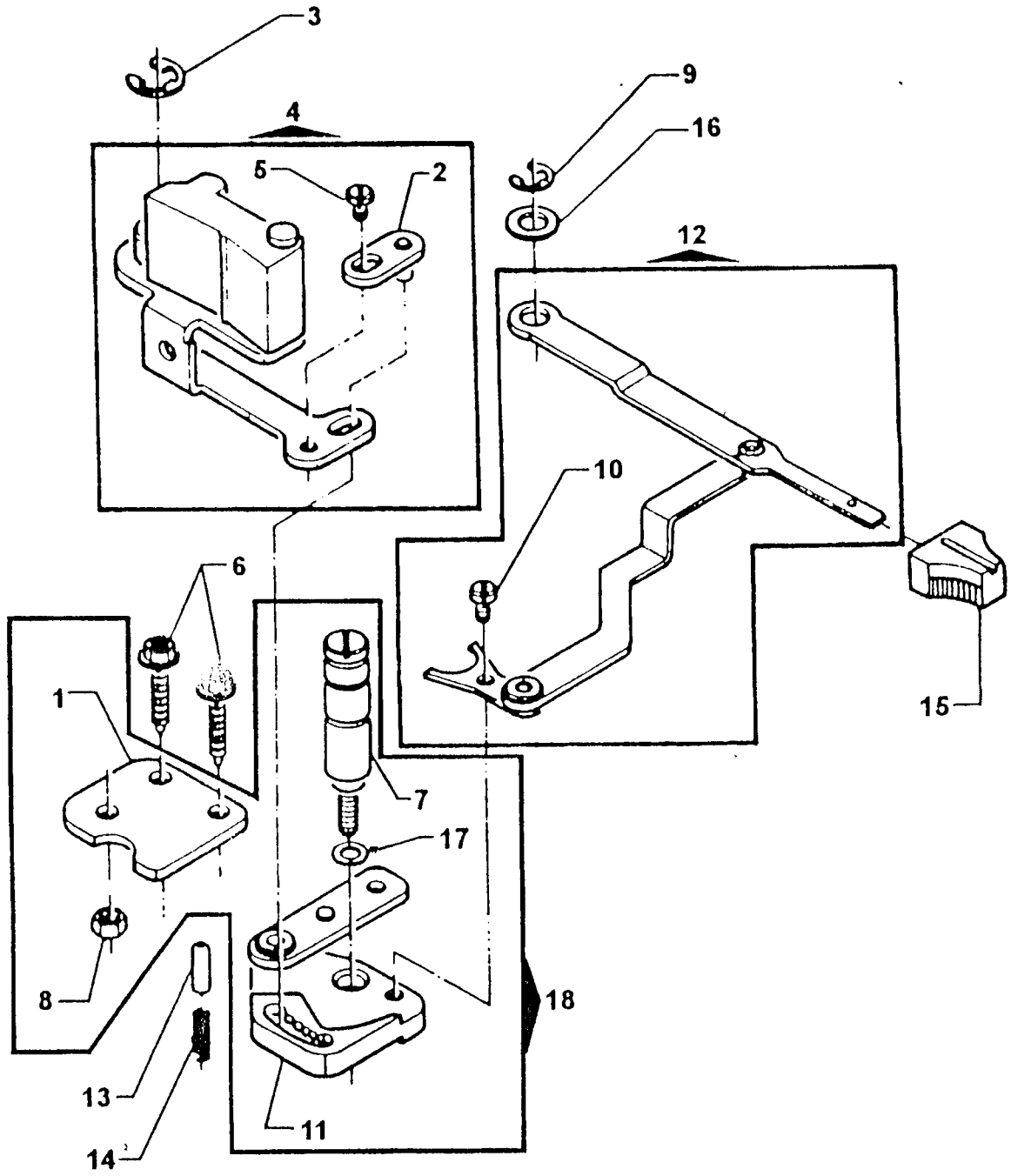

From the library of: Diamond Needle Corp

REV: _____
DATA: DEC/98

**PART LIST
NEEDLE POSITION**

9 9 9 5 C 9 9 9 9 9 9 5 9 9 9 5 9 9 9
 8 8 8 0 p 8 8 8 8 8 8 0 8 8 8 0 8 8 9
 0 0 0 1 1 0 0 1 1 1 1 2 1 2 2 4 3 3 3
 2 3 5 7 7 6 8 0 2 4 6 8 8 4 8 0 2 6 6

REF. PART NBR

DESCRIPTION

01	446401	NEEDLE POSITION SELECTOR LEVER ADJUSTING PLATE	X	X	X	X	X	X	X	X	X	X	X	X	X	X	X	X	X	X
02	531736	NEEDLE POSITION SELECTOR LEVER BRACKET FOLLOWER STUD ARM ASSEMBLY	X	X	X	X	X	X	X	X	X	X	X	X	X	X	X	X	X	X
03	445721	NEEDLE BAR DRIVING ARM SLIDE BRACKET RETAINING RING	X	X	X	X	X	X	X	X	X	X	X	X	X	X	X	X	X	X
04	356735-001	NEEDLE BAR DRIVING ARM SLIDE BRACKET COMPLETE	-	-	X	X	X	X	X	X	X	X	X	X	X	X	X	X	X	X
05	141913-451	NEEDLE POSITION LEVER BRACKET STUD ARM SET SCREW	X	X	X	X	X	X	X	X	X	X	X	X	X	X	X	X	X	X
06	113455-001	NEEDLE POSITION SELECTOR LEVER ADJUSTING PLATE SCREW	X	X	X	X	X	X	X	X	X	X	X	X	X	X	X	X	X	X
07	357089	DISC FOLLOWER STUD	-	-	X	X	X	X	X	X	X	X	X	X	X	X	X	X	X	X
08	54591-451	NEEDLE POSITION SELECTOR LEVER ADJUSTING PLATE SCREW NUT	X	X	X	X	X	X	X	X	X	X	X	X	X	X	X	X	X	X
09	445486	NEEDLE POSITION SELECTOR LEVER RETAINING RING	-	-	X	X	X	X	X	X	X	X	X	X	X	X	X	X	X	X
10	141913-451	NEEDLE POSITION SELECTOR LEVER SCREW	X	X	X	X	X	X	X	X	X	X	X	X	X	X	X	X	X	X
11	44628	NEEDLE POSITION SELECTOR LEVER BRACKET ASSEMBLY	-	-	X	X	X	X	X	X	X	X	X	X	X	X	X	X	X	X
12	356744	NEEDLE POSITION SELECTOR LEVER COMPLETE	-	-	X	X	X	X	X	X	X	X	X	X	X	X	X	X	X	X
13	356228	NEEDLE POSITION SELECTOR LEVER BRACKET POSITIONING PIN	X	X	X	X	X	X	X	X	X	X	X	X	X	X	X	X	X	X
14	444800	NEEDLE POSITION SELECTOR LEVER BRACKET POSITIONING PIN SPRING	X	X	X	X	X	X	X	X	X	X	X	X	X	X	X	X	X	X
15	356961-451	NEEDLE POSITION SELECTOR LEVER KNOB (PLASTIC) (SNOW WHITE)	X	X	X	X	X	X	X	X	X	X	X	X	X	X	X	X	X	X
16	49204	NEEDLE POSITION SELECTOR LEVER HINGE STUD WASHER	-	-	X	X	X	X	X	X	X	X	X	X	X	X	X	X	X	X
17	353585	DISC FOLLOWER STUD COLLAR	-	-	X	X	X	X	X	X	X	X	X	X	X	X	X	X	X	X
18	356838	NEEDLE POSITION SELECTOR LEVER BRACKET COMPLETE	-	-	X	X	X	X	X	X	X	X	X	X	X	X	X	X	X	X

From the original: Diamond Corp

<u>REF.</u>	<u>NEW P/N</u>	<u>IN PLACE OF</u>	<u>IMPLEMENTATION DATE</u>
04	356735-001	356735	10/27/92
07	357089	356774 900	07/20/93
11	44628	356943	10/27/92

9800 series, 5017 model, CP-17 model, 5028 and 5040 model.
 P/N 357669-001

Adopt.

NEEDLE POSITION

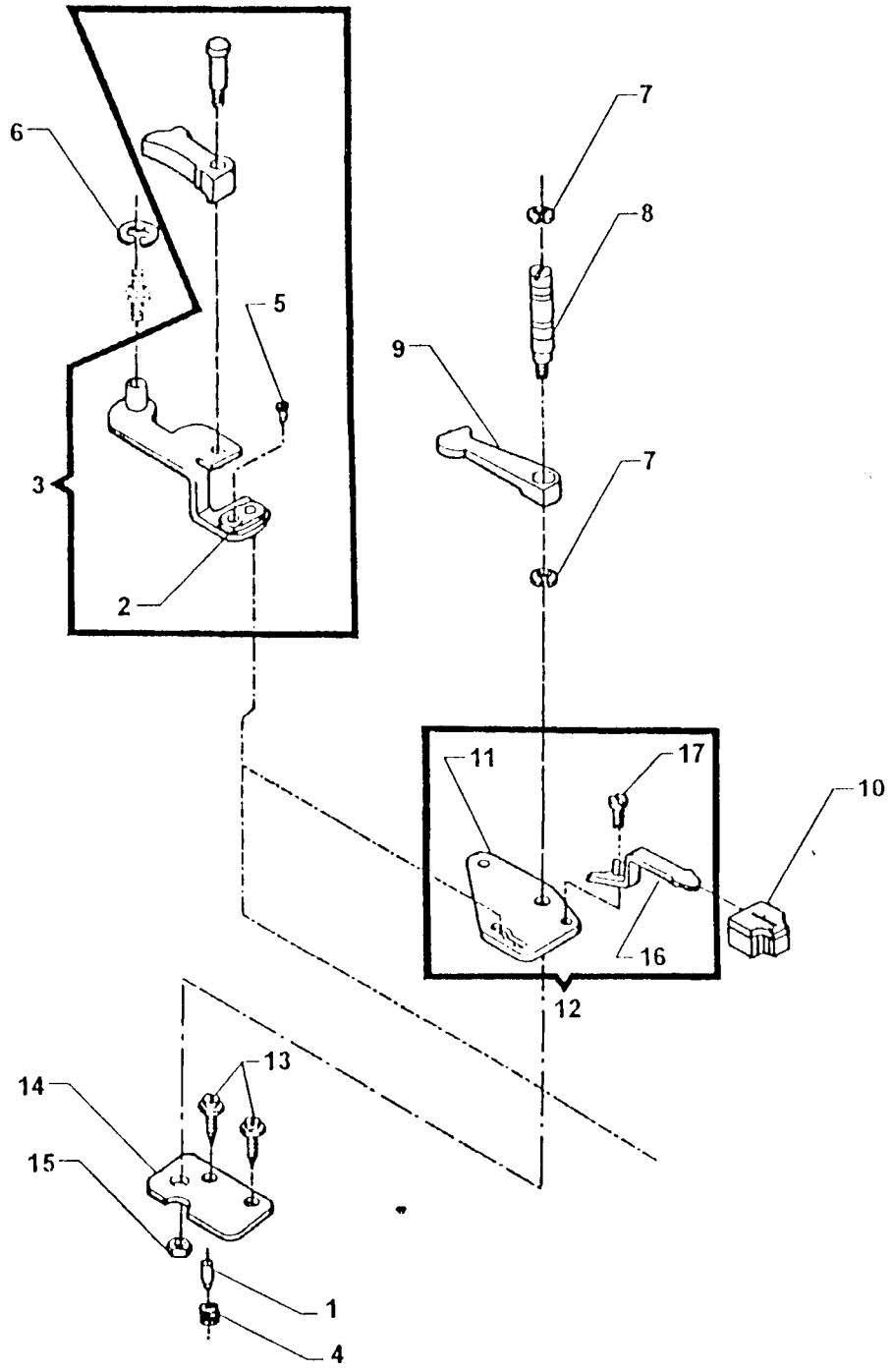

From the library of: Diamond Needle Corp

REV: _____
DATA: DEC/98

PART LIST
NEEDLE POSITION

9 9 9 5 C 9 9 9 9 9 9 5 9 9 5 9 9 9
 8 8 8 0 P 8 8 8 8 8 8 0 8 8 8 0 8 8 9
 0 0 0 1 1 0 0 1 1 1 1 2 1 2 2 4 3 3 3
 2 5 5 7 7 6 8 0 2 4 6 8 8 4 8 0 2 6 6

REF.	PART NBR	DESCRIPTION	9	9	9	5	C	9	9	9	9	9	9	5	9	9	5	9	9	9	9	9
01	356228	NEEDLE POSITION SELECTOR LEVER BRACKET POSITIONING PIN	X	X	X	X	X	X	X	X	X	X	X	X	X	X	X	X	X	X	X	X
02	531736	NEEDLE POSITION SELECTOR BRACKET FOLLOWER STUD ARM ASSEMBLY	X	X	X	X	X	X	X	X	X	X	X	X	X	X	X	X	X	X	X	X
03	356636	NEEDLE BAR DRIVING ARM SLIDE BRACKET COMPLETE	X	X	-	-	-	-	-	-	-	-	-	-	-	-	-	-	-	-	-	-
04	444800	NEEDLE POSITION SELECTOR LEVER BRACKET POSITIONING PIN SPRING	X	X	X	X	X	X	X	X	X	X	X	X	X	X	X	X	X	X	X	X
05	141913-451	NEEDLE POSITION LEVER BRACKET STUD ARM SET SCREW	X	X	X	X	X	X	X	X	X	X	X	X	X	X	X	X	X	X	X	X
06	445721	NEEDLE BAR DRIVING ARM SLIDE BRACKET RETAINING RING	X	X	X	X	X	X	X	X	X	X	X	X	X	X	X	X	X	X	X	X
07	44371	DISC FOLLOWER STUD RETAINING(UPPER & LOWER)	X	X	-	-	-	-	-	-	-	-	-	-	-	-	-	-	-	-	-	-
08	446023	DISC FOLLOWER STUD	X	X	-	-	-	-	-	-	-	-	-	-	-	-	-	-	-	-	-	-
09	445646	DISC FOLLOWER	X	X	-	-	-	-	-	-	-	-	-	-	-	-	-	-	-	-	-	-
10	356961-451	NEEDLE POSITION SELECTOR LEVER KNOB (PLASTIC) (SNOW WHITE)	X	X	X	X	X	X	X	X	X	X	X	X	X	X	X	X	X	X	X	X
11	353547	NEEDLE POSITION SELECTOR LEVER BRACKET	X	X	-	-	-	-	-	-	-	-	-	-	-	-	-	-	-	-	-	-
12	446399	NEEDLE POSITION SELECTOR LEVER ASSEMBLY	X	X	-	-	-	-	-	-	-	-	-	-	-	-	-	-	-	-	-	-
13	113455-001	NEEDLE POSITION SELECTOR LEVER MOUNTING PLATE SCREW	X	X	X	X	X	X	X	X	X	X	X	X	X	X	X	X	X	X	X	X
14	446401	NEEDLE POSITION SELECTOR LEVER MOUNTING PLATE	X	X	X	X	X	X	X	X	X	X	X	X	X	X	X	X	X	X	X	X
15	54591-451	DISC FOLLOWER STUD NUT	X	X	X	X	X	X	X	X	X	X	X	X	X	X	X	X	X	X	X	X
16	446397	NEEDLE POSITION SELECTOR LEVER	X	X	-	-	-	-	-	-	-	-	-	-	-	-	-	-	-	-	-	-
17	141913-451	NEEDLE POSITION SELECTOR LEVER SCREW	X	X	X	X	X	X	X	X	X	X	X	X	X	X	X	X	X	X	X	X

From the library of: Maxrod Needs Corp

9800 series, 5017 model, CP-17 model, 5028 and 5040 model.
 P/N 357669-001

Adopt.

PATTERN SELECTOR

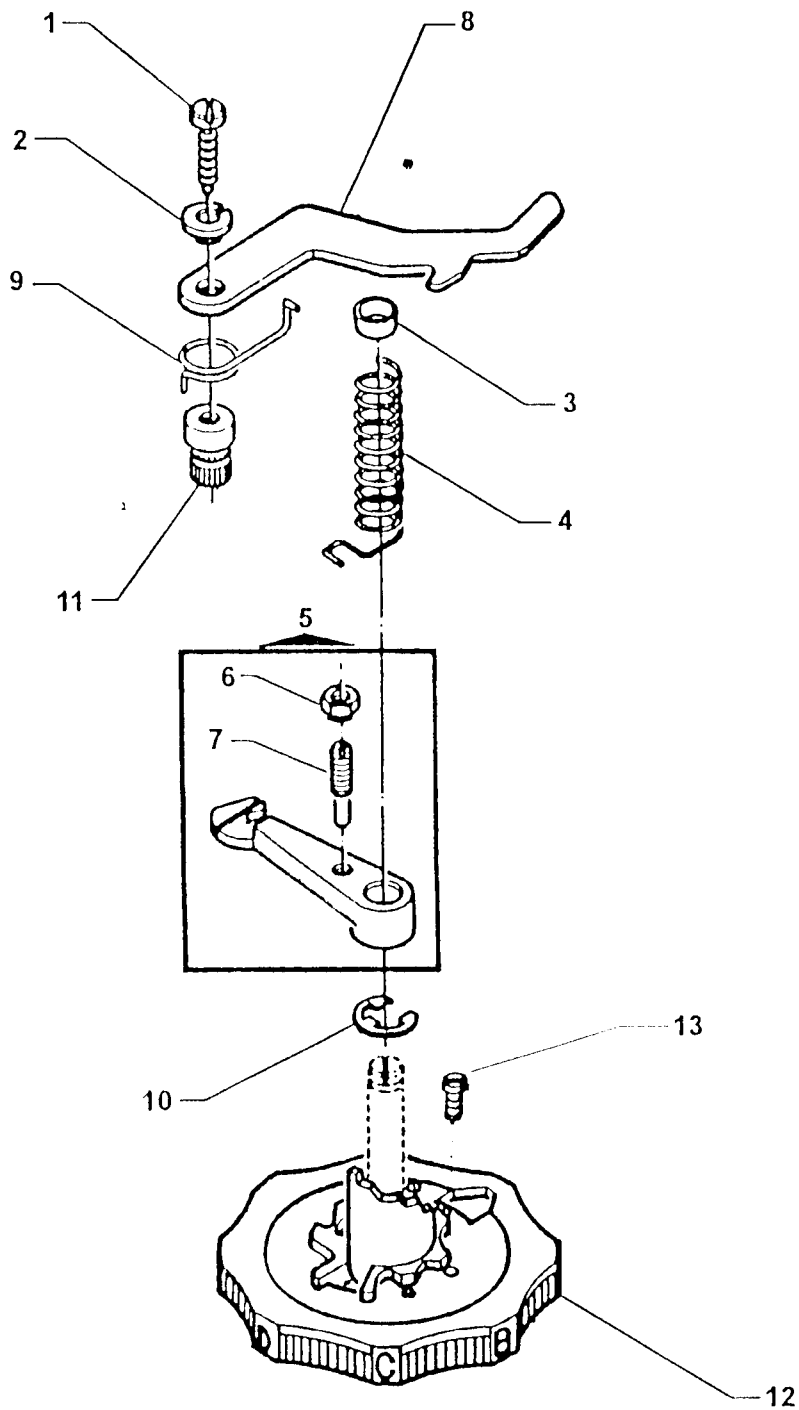

From the library of: Diamond Needle Corp

REV: _____
DATA: DEC 3

PART LIST
PATTERN SELECTOR

9 9 9 5 C 9 9 9 9 9 9 5 9 9 9 5 9 9 9
8 8 8 0 P 8 8 8 8 8 8 0 8 8 8 0 8 8 9
0 0 0 1 1 0 0 1 1 1 1 2 1 2 2 4 3 3 3
2 3 5 7 7 6 8 0 2 4 6 8 8 4 8 0 2 6 6

REF. PART NBR

DESCRIPTION

01	354826-451	DISC FOLLOWER DISENGAGING LEVER SCREW	-	-	X	X	X	X	X	X	X	X	X	X	X	X	X	X	X	X	X
02	356751	DISC FOLLOWER DISENGAGING LEVER BUSHING	-	-	X	X	X	X	X	X	X	X	X	X	X	X	X	X	X	X	X
03	353548	DISC FOLLOWER STUD WASHER	-	-	X	X	X	X	X	X	X	X	X	X	X	X	X	X	X	X	X
04	356768	DISC FOLLOWER SPRING	-	-	X	X	X	X	X	X	X	X	X	X	X	X	X	X	X	X	X
05	356770	DISC FOLLOWER COMPLETE	-	-	X	X	X	X	X	X	X	X	X	X	X	X	X	X	X	X	X
06	531699-451	DISC FOLLOWER ADJUSTING SCREW STUD NUT	-	-	X	X	X	X	X	X	X	X	X	X	X	X	X	X	X	X	X
07	445341	DISC FOLLOWER ADJUSTING SCREW STUD	-	-	X	X	X	X	X	X	X	X	X	X	X	X	X	X	X	X	X
08	356750	DISC FOLLOWER DISENGAGING LEVER	-	-	X	X	X	X	X	X	X	X	X	X	X	X	X	X	X	X	X
09	356752	DISC FOLLOWER DISENGAGING LEVER SPRING	-	-	X	X	X	X	X	X	X	X	X	X	X	X	X	X	X	X	X
10	603908-001	DISC SELECTOR CAM RETAINING RING	-	-	X	X	X	X	X	X	X	X	X	X	X	X	X	X	X	X	X
11	357000	DISC FOLLOWER DISENGAGING LEVER STUD	-	-	X	X	X	X	X	X	X	X	X	X	X	X	X	X	X	X	X
12	356749-454	PATTERN SELECTOR CAM/DIAL (SNOW WHITE) FOR 9818/9836/9936	-	-	-	-	-	-	-	-	-	-	-	X	-	-	-	-	X	X	-
12	356749-455	PATTERN SELECTOR CAM/DIAL (SNOW WHITE) FOR 9816/9832	-	-	-	-	-	-	-	-	-	-	X	X	-	-	-	-	X	-	-
12	356749-456	PATTERN SELECTOR CAM/DIAL (SNOW WHITE) FOR 9814/9828	-	-	-	-	-	-	-	-	X	-	-	-	-	X	X	-	-	-	-
12	356749-457	PATTERN SELECTOR CAM/DIAL (SNOW WHITE) FOR 9812/9824	-	-	-	-	-	-	-	X	-	-	-	-	X	-	-	-	-	-	-
12	356749-458	PATTERN SELECTOR CAM/DIAL (SNOW WHITE) FOR 9805/9810	-	-	X	X	X	-	-	X	-	-	-	-	-	-	-	-	-	-	-
12	356749-459	PATTERN SELECTOR CAM/DIAL (SNOW WHITE) FOR 9808	-	-	-	-	-	-	X	-	-	-	-	-	-	-	-	-	-	-	-
12	356749-460	PATTERN SELECTOR CAM/DIAL (SNOW WHITE) FOR 9806	-	-	-	-	-	-	X	-	-	-	-	-	-	-	-	-	-	-	-
13	355247-451	PATTERN SELECTOR CAM POSITIONER SCREW	-	-	X	X	X	X	X	X	X	X	X	X	X	X	X	X	X	X	-

From the library of: Diamond Needle Corp.

<u>REF.</u>	<u>NEW P/N</u>	<u>IN PLACE OF</u>	<u>IMPLEMENTATION DATE</u>
10	603908-001	444921	08/10/93

9800 series, 5017 model, CP-17 model, 5028 and 5040 model.
P/N 357669-001

Adopt.

CAM STACK

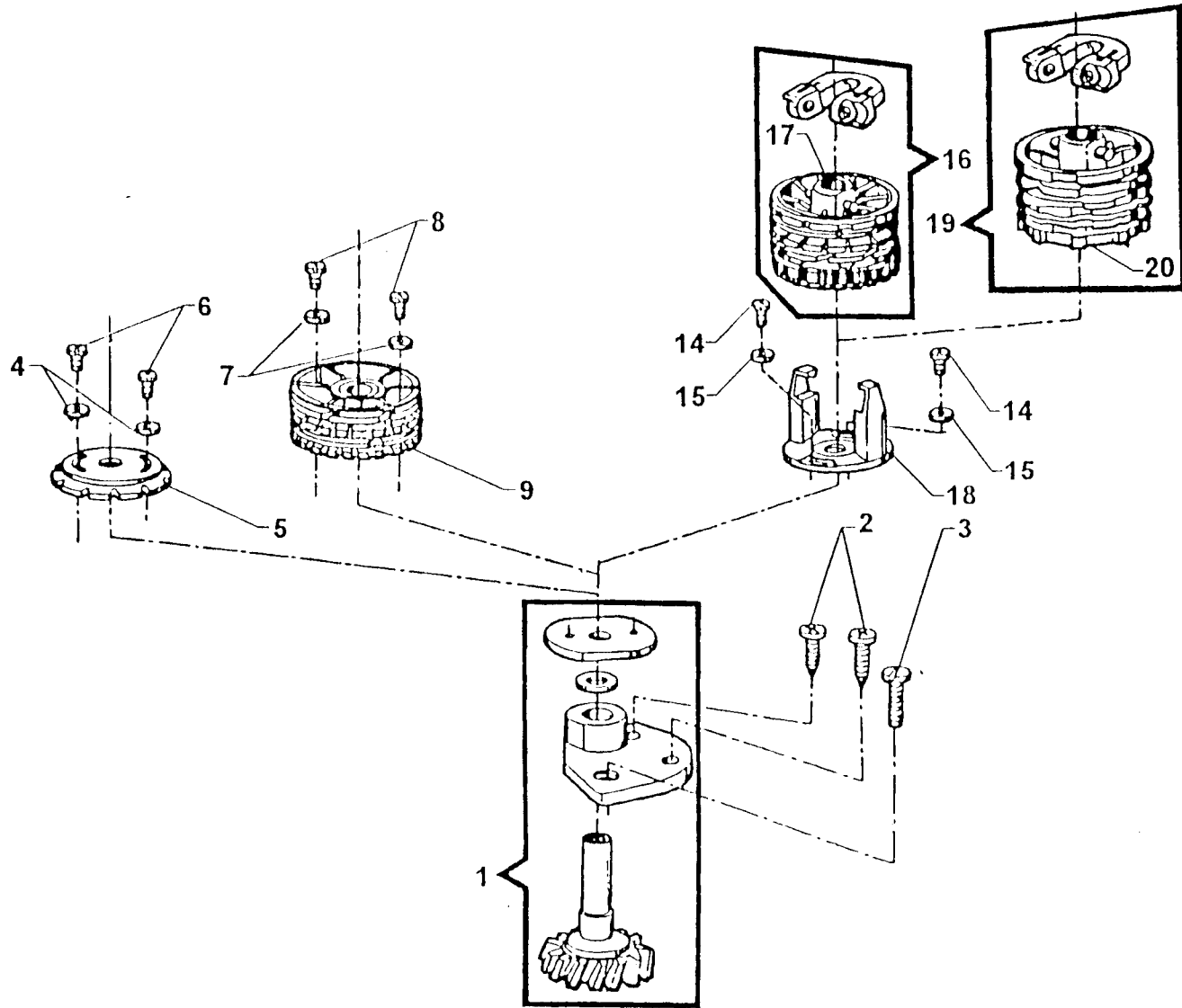

From the library of: Diamond Needle Corp

REV _____
DATA: DEC/98

**PART LIST
CAM STACK**

9 9 9 5 C 9 9 9 9 9 9 5 9 9 9 5 9 9 9
 8 8 8 0 P 8 8 8 8 8 8 0 8 8 8 0 8 8 9
 0 0 0 1 1 0 0 1 1 1 1 2 1 2 2 4 3 3 3
 2 3 5 7 7 6 8 0 2 4 6 8 8 4 8 0 2 6 6

REF. PART NBR

DESCRIPTION

01	356982	DISC DRIVING GEAR SHAFT MOUNTING PLATE ASSEMBLY	X	X	X	X	X	X	X	X	X	X	X	X	X	X	X	X	X	X
02	113455-012	DISC DRIVING GEAR SHAFT MOUNTING PLATE SCREW	X	X	X	X	X	X	X	X	X	X	X	X	X	X	X	X	X	X
03	113455-012	DISC DRIVING GEAR SHAFT MOUNTING PLATE SCREW	X	X	X	X	X	X	X	X	X	X	X	X	X	X	X	X	X	X
04	356830-003	DISC STACK POSITIONING SCREW WASHER	X	X	X	X	X	X	X	X	X	X	X	X	X	X	X	X	X	X
05	356999	DISC STACK (PLASTIC)	X	X	-	-	-	-	-	-	-	-	-	-	-	-	-	-	-	-
06	141920-451	DISC STACK POSITIONING SCREW	X	X	X	X	X	X	X	X	X	X	X	X	X	X	X	X	X	X
07	356830-003	DISC STACK POSITIONING SCREW WASHER	X	X	X	X	X	X	X	X	X	X	X	X	X	X	X	X	X	X
08	141920-451	DISC STACK POSITIONING SCREW	X	X	X	X	X	X	X	X	X	X	X	X	X	X	X	X	X	X
09	356995	DISC STACK (PLASTIC)	-	-	X	X	X	X	X	-	-	-	-	-	-	-	-	-	-	-
14	141920-451	DISC STACK PLATE SCREW	X	X	X	X	X	X	X	X	X	X	X	X	X	X	X	X	X	X
15	356830-003	DISC STACK PLATE SCREW WASHER	X	X	X	X	X	X	X	X	X	X	X	X	X	X	X	X	X	X
16	357016	DISC STACK ASSEMBLY	-	-	-	-	-	-	-	X	X	X	X	X	X	X	X	X	X	X
17	356969	DISC STACK (PLASTIC)	-	-	-	-	-	-	-	X	X	X	X	X	X	X	X	X	X	X
18	356971	DISC DRIVING PLATE	-	-	-	-	-	-	-	X	X	X	X	X	X	X	X	X	X	X
19	357021	DISCK STACK ASSEMBLY (ACCESSORIES)	-	-	-	-	-	-	-	-	-	-	-	-	-	-	X	X	X	X
20	356970	DISC STACK (PLASTIC) (ACCESSORIES)	-	-	-	-	-	-	-	-	-	-	-	-	-	-	X	X	X	X

From the library of: Diamond Machine Corp

<u>REF.</u>	<u>NEW P/N</u>	<u>IN PLACE OF</u>	<u>IMPLEMENTATION DATE</u>
03	113455-012	113435-451	03/12/92
04	356830-003	179957-451	12/01/92
06	141920-451	141920-452	11/21/94
07	356830-003	179957-451	12/01/92
08	141920-451	141920-452	11/21/94
11	356830-003	179957-451	12/01/94
12	356999	356969	03/25/92
14	141920-451	141920-452	11/21/94

9800 series, 5017 model, CP-17 model, 5028 and 5040 model.
 P/N 357669-001

Adopt.

FEED REGULATOR CAM

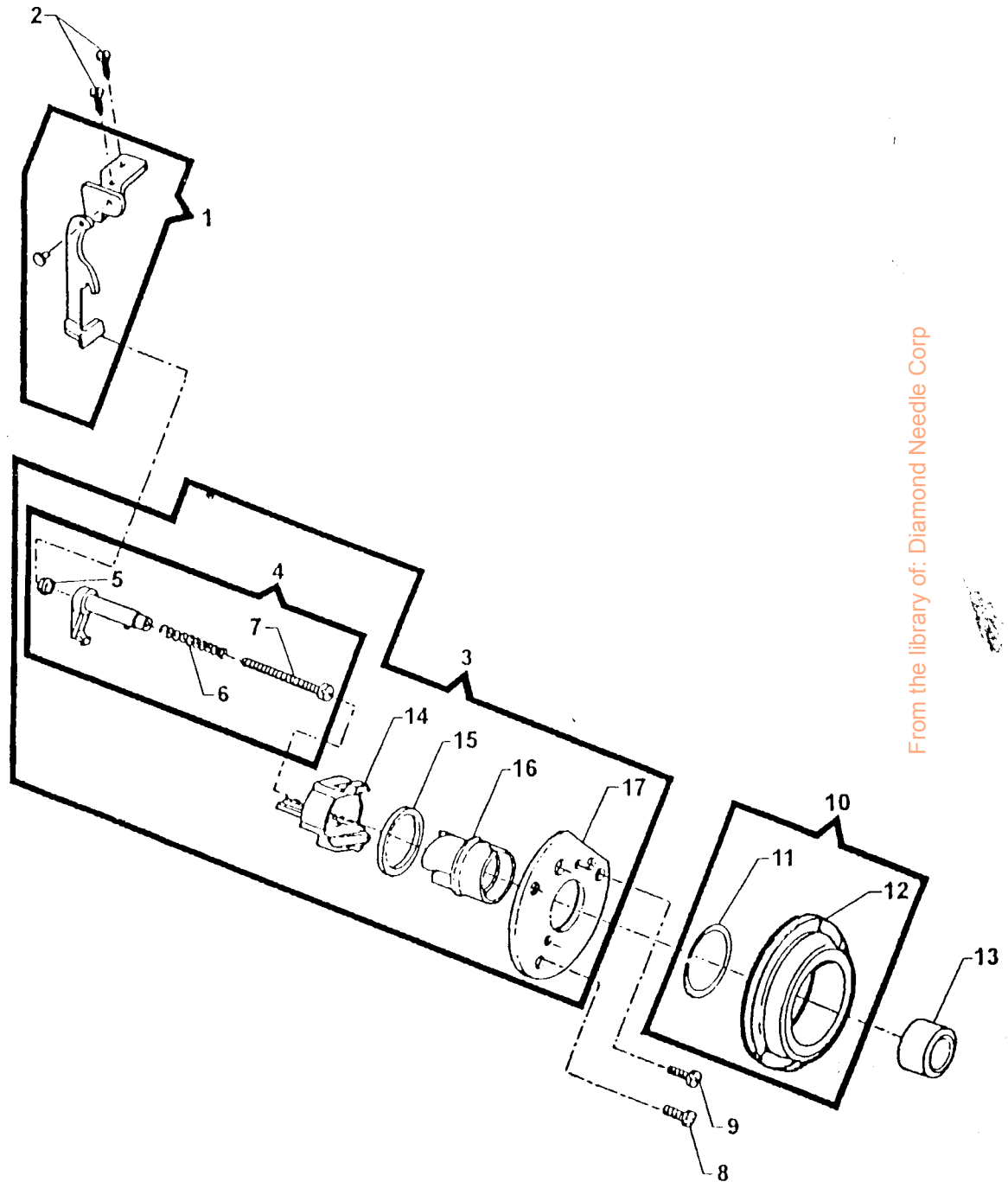

From the library of: Diamond Needle Corp

REV: _____
DATA: DEC/98

PART LIST
FEED REGULATOR CAM

9 9 9 5 C 9 9 9 9 9 9 5 9 9 5 5 9 9 9
8 8 8 0 P 8 8 8 8 8 8 0 8 8 8 0 8 8 9
0 0 0 1 1 0 0 1 1 1 1 2 1 2 2 4 3 3 3
2 3 5 7 7 6 8 0 2 4 6 8 8 4 8 0 2 6 6

REF. PART NBR

DESCRIPTION

01	353304	FEED REGULATOR CONTROL ARM ASSEMBLY	X	X	X	X	X	X	X	X	X	X	X	X	X	X	X	X	X
02	113455-001	FEED REGULATOR CONTROL ARM MOUNTING BRACKET SCREW	X	X	X	X	X	X	X	X	X	X	X	X	X	X	X	X	X
03	353478	FEED REGULATOR CAM COMPLETE	X	X	-	-	-	-	-	-	-	-	-	-	-	-	-	-	-
04	356397	FEED REGULATOR CAM FOLLOWER	X	X	-	-	-	-	-	-	-	-	-	-	-	-	-	-	-
05	618638-005	FEED REGULATOR CAM FOLL OWER POSITIONING SPRING NUT	X	X	X	X	X	X	X	X	X	X	X	X	X	X	X	X	X
06	44892	FEED REGULATOR CAM FOLLOWER POSITIONING SPRING	X	X	X	X	X	X	X	X	X	X	X	X	X	X	X	X	X
07	354975-451	FEED REGULATOR CAM FOLLOWER POSITIONG SCREW	X	X	-	-	-	-	-	-	-	-	-	-	-	-	-	-	-
08	531806-451	FEED REGULATOR MOUNTING PLATE SCREW (RIGHT)	X	X	-	-	-	-	-	-	-	-	-	-	-	-	-	-	-
09	531807-451	FEED REGULATOR MOUNTING PLATE SCREW (LEFT)	X	X	-	-	-	-	-	-	-	-	-	-	-	-	-	-	-
10	356998-451	FEED REGULATOR CONTROL DIAL ASSEMBLY	X	X	-	-	-	-	-	-	-	-	-	-	-	-	-	-	-
11	445461	FEED REGULATOR CONTROL DIAL RETAINING RING	X	X	-	-	-	-	-	-	-	-	-	-	-	-	-	-	-
12	356997-451	FEED REGULATOR CONTROL DIAL	X	X	-	-	-	-	-	-	-	-	-	-	-	-	-	-	-
13	356115-452	FEED REGULATOR POSITIONING PIN KNOB	X	X	-	-	-	-	-	-	-	-	-	-	-	-	-	-	-
14	446284	FEED REGULATOR MOUNTING PLATE	X	X	-	-	-	-	-	-	-	-	-	-	-	-	-	-	-
15	446282	FEED REGULATOR FRICTION WASHER	X	X	-	-	-	-	-	-	-	-	-	-	-	-	-	-	-
16	353477	FEED REGULATOR CAM	X	X	-	-	-	-	-	-	-	-	-	-	-	-	-	-	-
17	446283	FEED REGULATOR MECHANISM MOUNTING PLATE	X	X	-	-	-	-	-	-	-	-	-	-	-	-	-	-	-

From the library of: Diamond Needle Corp

9800 series, 5017 model, CP-17 model, 5028 and 5040 model.
P/N 357669-001

Adopt.

BUTTONHOLER & FEED REGULATOR CAM

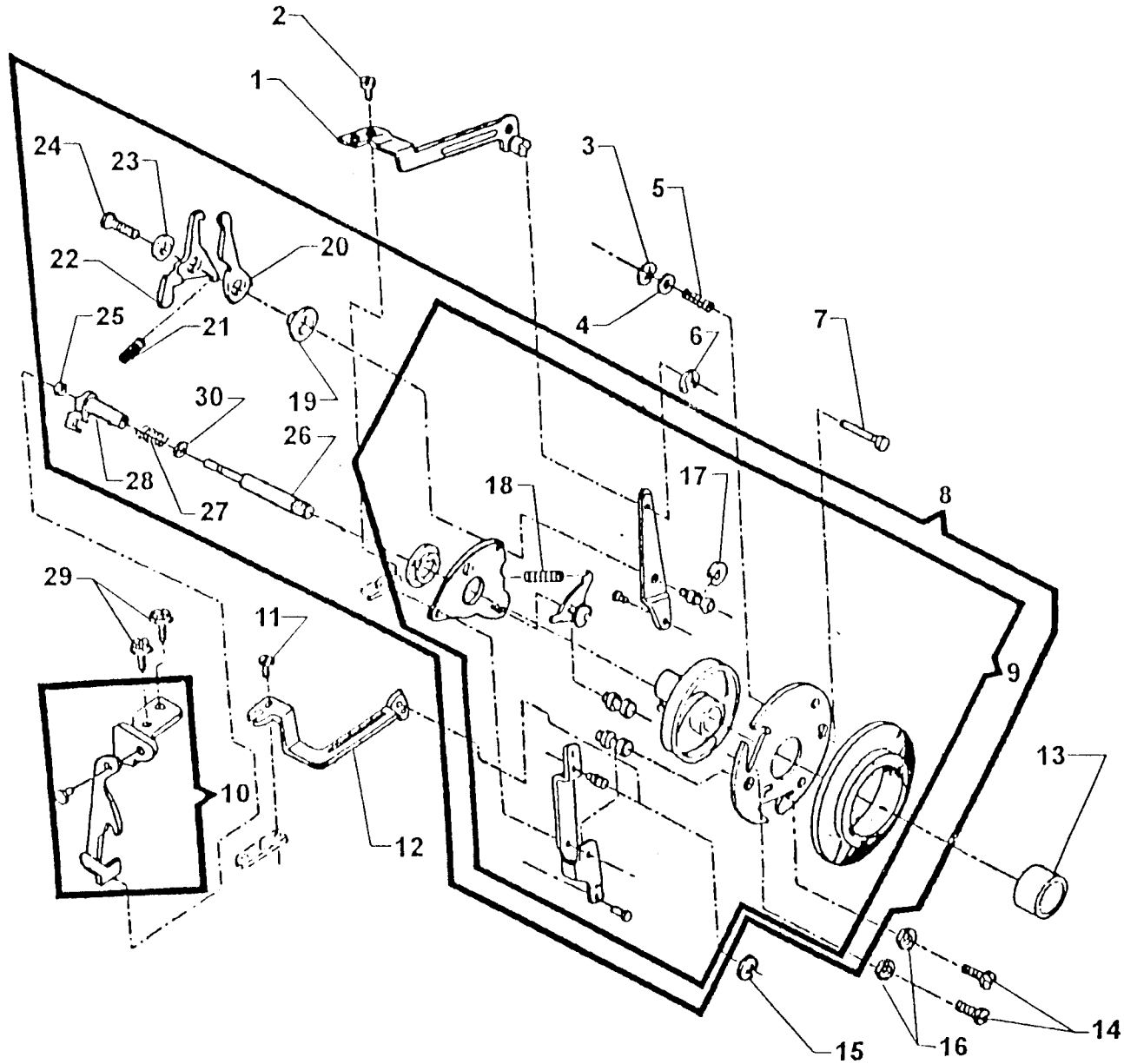

From the library of: Diamond Needle Corp

REV: _____
DATA: DEC/98

CAM CONTROLLED FEED

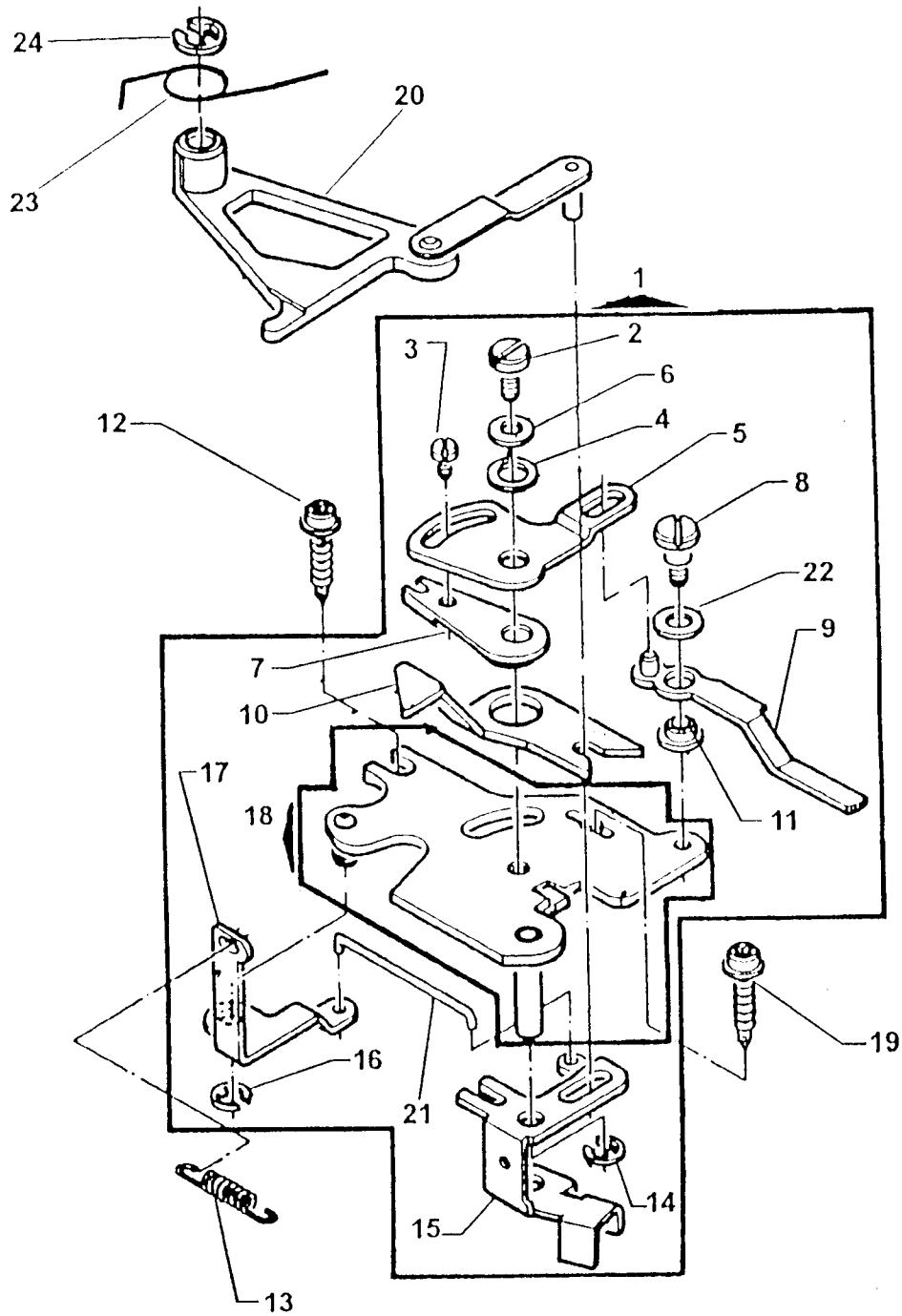

From the library of: Diamond Needle Corp

REV: _____
DATA: DEC/98

**PART LIST
CAM CONTROLLED FEED**

9 9 9 5 C 9 9 9 9 9 9 5 9 9 9 5 9 9 9
 8 8 8 0 P 8 8 8 8 8 8 0 8 8 8 0 8 8 9
 0 0 0 1 1 0 0 1 1 1 1 2 1 2 2 4 3 3 3
 2 3 5 7 7 6 8 0 2 4 6 8 8 4 8 0 2 6 6

REF. PART NBR

DESCRIPTION

01	531749-001	CAM CONTROLLED FEED MOUNTING BRACKET COMPLETE	-	-	-	-	-	-	X	X	X	X	X	X	-	X	X	X	-	X	X	X
02	113423-451	CAM CONTROLLED FEED BALANCE ADJUSTING PLATE HINGE SCREW	-	-	-	-	-	-	X	X	X	X	X	X	-	X	X	X	-	X	X	X
03	141913-451	CAM CONTROLLED FEED BALANCE ADJUSTING SCREW	-	-	-	-	-	-	X	X	X	X	X	X	-	X	X	X	-	X	X	X
04	353492	CAM CONTROLLED FEED BALANCE ADJUSTING SCREW SPRING WASHER	-	-	-	-	-	-	X	X	X	X	X	X	-	X	X	X	-	X	X	X
05	531754	CAM CONTROLLED FEED BALANCE ADJUSTING PLATE	-	-	-	-	-	-	X	X	X	X	X	X	-	X	X	X	-	X	X	X
06	543531	CAM CONTROLLEDD FEED BALANCE ADJUSTING SCREW WASHER	-	-	-	-	-	-	X	X	X	X	X	X	-	X	X	X	-	X	X	X
07	353331	CAM CONTROLLED FEED DRIVING ARM ECCENTRIC	-	-	-	-	-	-	X	X	X	X	X	X	-	X	X	X	-	X	X	X
08	113424-451	CAM CONTROLLED FEED BALANCE ADJUSTING LEVER HINGE SCREW	-	-	-	-	-	-	X	X	X	X	X	X	-	X	X	X	-	X	X	X
09	531752-453	CAM CONTROLLED FEED BALANCE ADJUSTING LEVER ASSEMBLY	-	-	-	-	-	-	X	X	X	X	X	X	-	X	X	X	-	X	X	X
10	353330-001	CAM CONTROLLED FEED DRIVING ARM	-	-	-	-	-	-	X	X	X	X	X	X	-	X	X	X	-	X	X	X
11	353334	CAM CONTROLLED FEED BALANCE ADJUSTING LEVER MOUNTING BUSHING	-	-	-	-	-	-	X	X	X	X	X	X	X	X	X	X	X	X	X	X
12	355243-451	CAM CONTROLLED FEED MOUNTING BRACKET SCREW	-	-	-	-	-	-	X	X	X	X	X	X	X	X	X	X	X	X	X	X
13	356605	FEED REGULATOR CONTROL ARM BIAS LINK SPRING	-	-	-	-	-	-	X	X	X	X	X	X	X	X	X	X	X	X	X	X
14	445721	CAM CONTROLLED FEED ENGAGING CRANK RETAINING RING	-	-	-	-	-	-	X	X	X	X	X	X	X	X	X	X	X	X	X	X
15	353329	CAM CONTROLLED FEED ENGAGING CRANK	-	-	-	-	-	-	X	X	X	X	X	X	X	X	X	X	X	X	X	X
16	445486	CAM CONTROLLED FEED FOLLOWER & LINK RETAINING RING	-	-	-	-	-	-	X	X	X	X	X	X	X	X	X	X	X	X	X	X
17	356166	CAM CONTROLLED FEED ENGAGING CRANK LEVER	-	-	-	-	-	-	X	X	X	X	X	X	X	X	X	X	X	X	X	X
18	531750	CAM CONTROLLED FEED MOUNTING BRACKET ASSEMBLY	-	-	-	-	-	-	X	X	X	X	X	X	X	X	X	X	X	X	X	X
19	113455-003	CAM CONTROLLED FEED MOUNTING BRACKET SCREW (RIGHT)	-	-	-	-	-	-	X	X	X	X	X	X	X	X	X	X	X	X	X	X
20	356839	CAM CONTROLLED FEED FOLLOWER & LINK ASSEMBLY	-	-	-	-	-	-	X	X	X	X	X	X	X	X	X	X	X	X	X	X
21	353473	CAM CONTROLLED FEED ENGAGING CRANK LINK	-	-	-	-	-	-	X	X	X	X	X	X	X	X	X	X	X	X	X	X
22	179898-001	CAM CONTROLLED FEED BALANCE ADJUSTING LEVER WASHER	-	-	-	-	-	-	X	X	X	X	X	X	X	X	X	X	X	X	X	X
23	357003	CAM CONTROLLED FEED FOLLOWER DISENGAGING SPRING	-	-	-	-	-	-	-	-	-	-	-	-	-	-	X	X	X	X	X	X
24	445486	CAM CONTROLLED FEED FOLLOWER & LINK ASSEMBLY RETAINING RING	-	-	-	-	-	-	X	X	X	X	X	X	X	X	X	X	X	X	X	X

From the library of: James Neely Co.

<u>REF.</u>	<u>NEW P/N</u>	<u>IN PLACE OF</u>	<u>IMPLEMENTATION DATE</u>
01	531749-001	531749	11/24/92
09	531752-453	531752-452	11/24/92

FEED SYSTEM

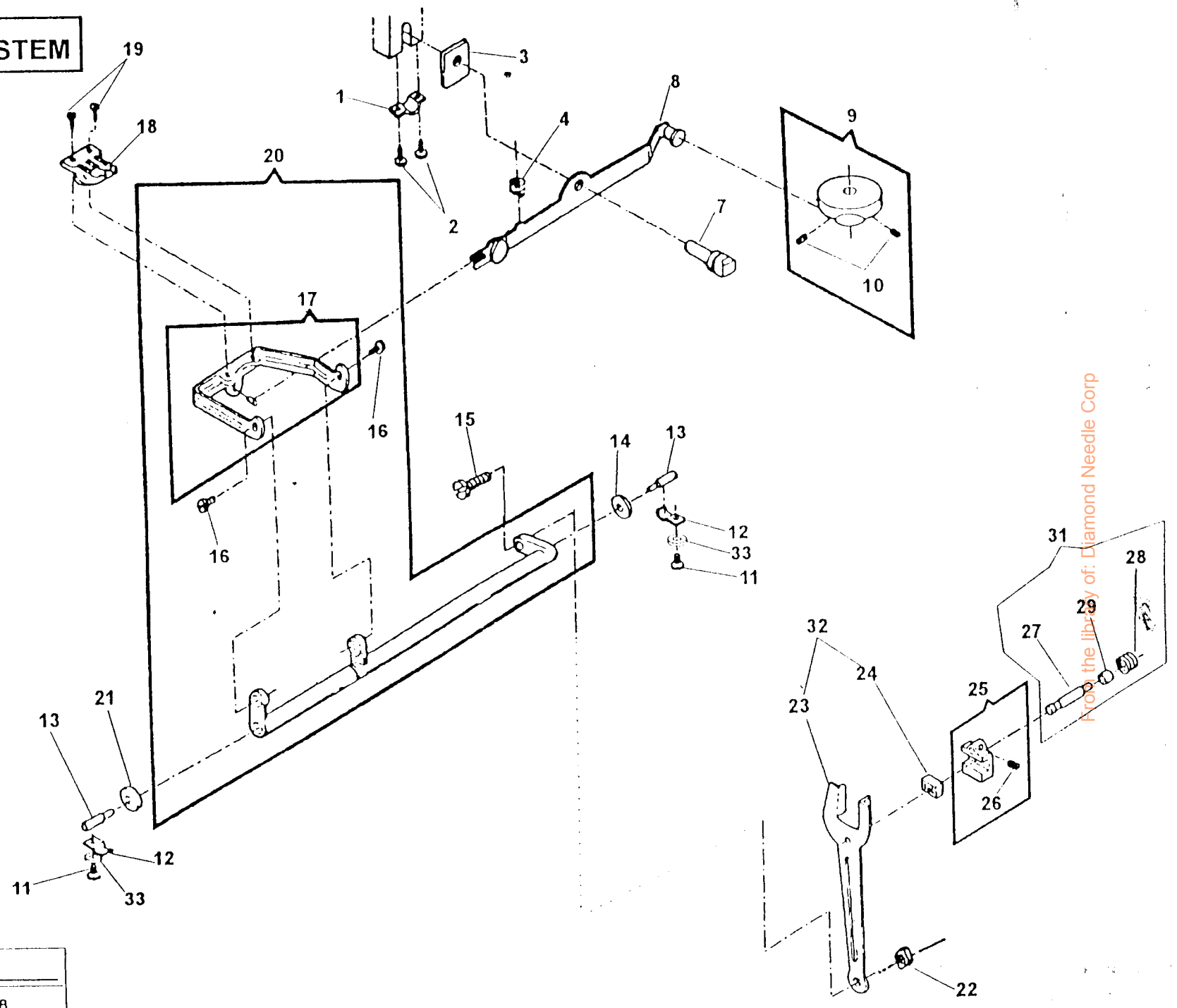

From the library of: Diamond Needle Corp

REV: _____
DATA: _DEC/98

**PART LIST
FEED SYSTEM**

9 9 9 5 C 9 9 9 9 9 9 5 9 9 9 5 9 9 9
 8 8 8 0 P 8 8 8 8 8 8 0 8 8 8 0 8 8 9
 0 0 0 1 1 0 0 1 1 1 1 2 1 2 2 4 3 3 3
 2 3 5 7 7 6 8 0 2 4 6 8 8 4 8 0 2 6 6

REF. PART NBR

DESCRIPTION

01	446485	FEED LIFTING LEVER HINGE STUD (ECCENTRIC) CLAMP	X	X	X	X	X	X	X	X	X	X	X	X	X	X	X	X	X
02	113455-001	FEED LIFTING LEVER HINGE STUD (ECCENTRIC) CLAMP SCREW	X	X	X	X	X	X	X	X	X	X	X	X	X	X	X	X	X
03	179955	FEED LIFTING LEVER HINGE STUD (ECCENTRIC) SPACER	X	X	X	X	X	X	X	X	X	X	X	X	X	X	X	X	X
04	446249	FEED LIFTING LEVER SPRING	X	X	X	X	X	X	X	X	X	X	X	X	X	X	X	X	X
07	357122-001	FEED LIFTING LEVER HINGE STUD (ECCENTRIC)	X	X	X	X	X	X	X	X	X	X	X	X	X	X	X	X	X
08	356222	FEED LEFTING LEVER ASSEMBLY	X	X	X	X	X	X	X	X	X	X	X	X	X	X	X	X	X
09	446228	FEED LIFTING CAM	X	X	X	X	X	X	X	X	X	X	X	X	X	X	X	X	X
10	544118	FEED LIFTING CAM SCREW	X	X	X	X	X	X	X	X	X	X	X	X	X	X	X	X	X
11	113455-001	FEED ROCK SHAFT CENTER SUPPORTING BRACKET SCREW	X	X	X	X	X	X	X	X	X	X	X	X	X	X	X	X	X
12	446484	FEED ROCK SHAFT CENTER CLAMP (LEFT & RIGHT)	X	X	X	X	X	X	X	X	X	X	X	X	X	X	X	X	X
13	446487-001	FEED ROCK SHAFT CENTER	X	X	X	X	X	X	X	X	X	X	X	X	X	X	X	X	X
14	353397	FEED ROCK SHAFT CENTER (RIGHT) NOISE DAMPENING WASHER	X	X	X	X	X	X	X	X	X	X	X	X	X	X	X	X	X
15	531623-451	FEED FORKED CONNECTION HINGE SCREW (ECCENTRIC)	X	X	X	X	X	X	X	X	X	X	X	X	X	X	X	X	X
16	354939-451	FEED BAR HINGE SCREW	X	X	X	X	X	X	X	X	X	X	X	X	X	X	X	X	X
17	446205	FEED BAR ASSEMBLY	X	X	X	X	X	X	X	X	X	X	X	X	X	X	X	X	X
18	179891	FEED DOG	X	X	X	X	X	X	X	X	X	X	X	X	X	X	X	X	X
19	355235-451	FEED DOG SCREW	X	X	X	X	X	X	X	X	X	X	X	X	X	X	X	X	X
20	446216	FEED ROCK SHAFT COMPLETE	X	X	X	X	X	X	X	X	X	X	X	X	X	X	X	X	X
21	353397	FEED ROCK SHAFT CENTER (LEFT) NOISE DAMPENING WASHER	X	X	X	X	X	X	X	X	X	X	X	X	X	X	X	X	X
22	53648-451	FEED FORKED CONNECTION SCREW STUD NUT	X	X	X	X	X	X	X	X	X	X	X	X	X	X	X	X	X
23	531926	FEED FORKED CONNECTION	X	X	X	X	X	X	X	X	X	X	X	X	X	X	X	X	X
24	44437	FEED FORKED CONNECTION SLIDE BLOCK	X	X	X	X	X	X	X	X	X	X	X	X	X	X	X	X	X
25	446244	FEED REGULATOR ASSEMBLY	X	X	X	X	X	X	X	X	X	X	X	X	X	X	X	X	X
26	141925-833	FEED REGULATOR SET SCREW	X	X	X	X	X	X	X	X	X	X	X	X	X	X	X	X	X
27	446483	FEED REGULATOR HINGE STUD	X	X	X	X	X	X	X	X	X	X	X	X	X	X	X	X	X
28	179890	FEED REGULATOR RETURN SPRING	X	X	X	X	X	X	X	X	X	X	X	X	X	X	X	X	X
29	445768	FEED REGULATOR RETURN SPRING BUSHING (PLASTIC)	X	X	X	X	X	X	X	X	X	X	X	X	X	X	X	X	X
31	353600	FEED REGULATOR HINGE STUD ASSEMBLY	X	X	X	X	X	X	X	X	X	X	X	X	X	X	X	X	X
32	531927	FEED FORKED CONNECTION WITH SLIDE BLOCK	X	X	X	X	X	X	X	X	X	X	X	X	X	X	X	X	X
33	353357-451	FEED ROCK SHAFT CENTER SUP. BRACKET SCREW WASHER	X	X	X	X	X	X	X	X	X	X	X	X	X	X	X	X	X

From the library of: Diamond Needle Corp.

<u>REF.</u>	<u>NEW P/N</u>	<u>IN PLACE OF</u>	<u>IMPLEMENTATION DATE</u>
05	-----	353427	07/30/97
06	-----	353428	07/30/97
07	357122	353448	07/30/97

9800 series, 5017 model, CP-17 model, 5028 and 5040 model.
 P/N 357669-001

Adopt.

ELECTRICAL EQUIPMENT

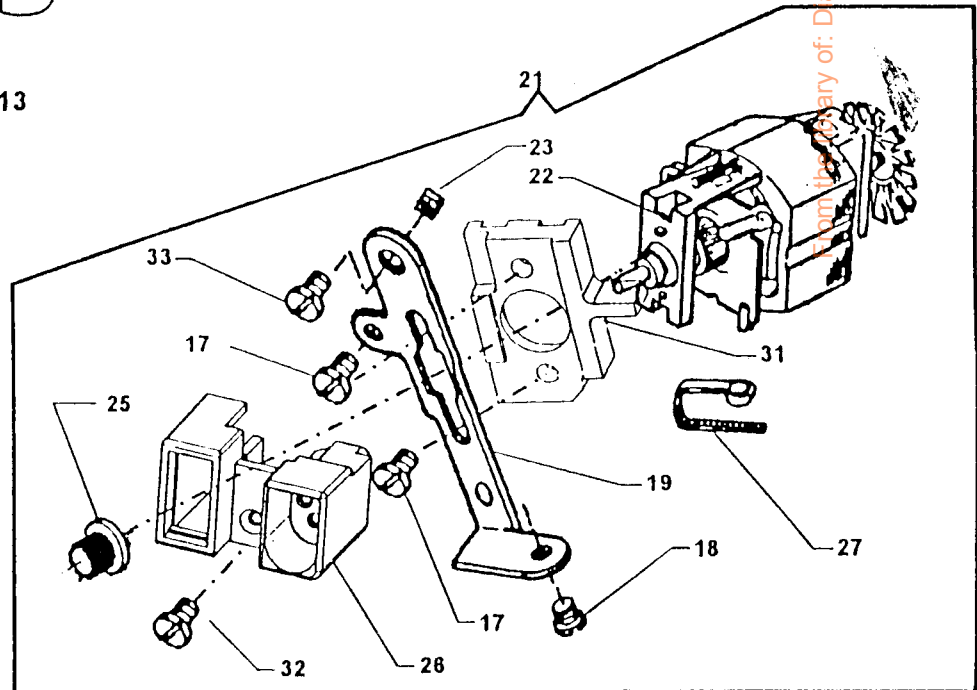
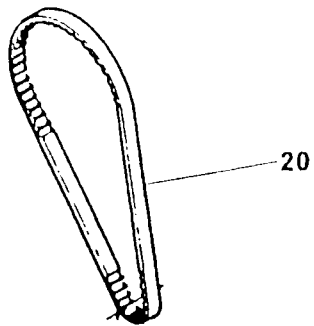
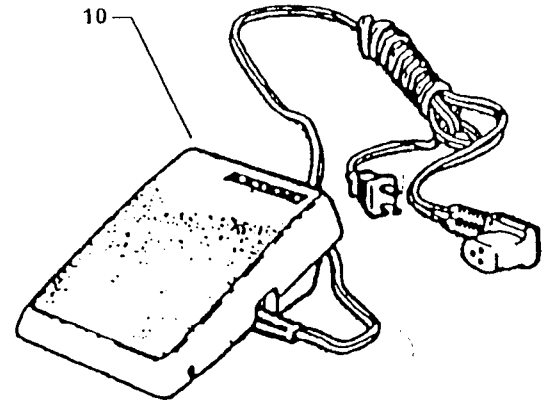
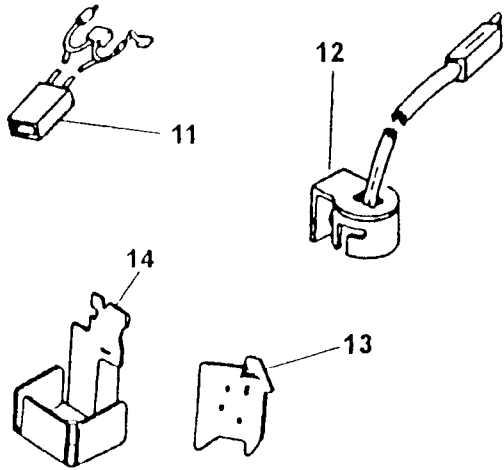
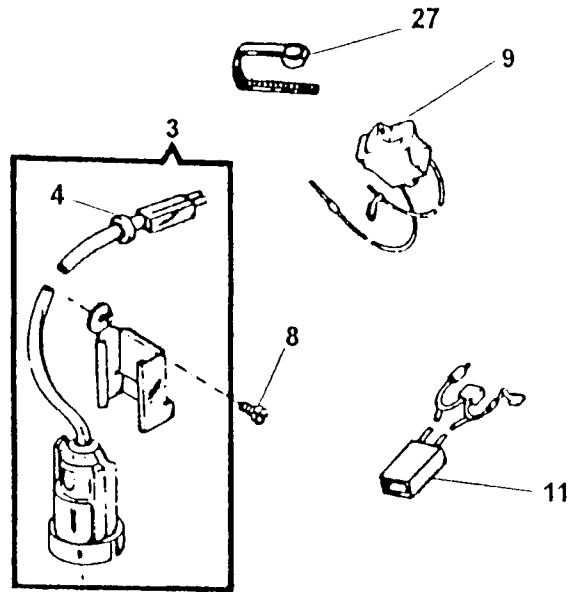

REV: _____
DATE: DEC/98

Property of: Diamond Needle Corp

**PART LIST
ELECTRICAL EQUIPMENT**

9 9 9 5 C 9 9 9 9 9 9 5 9 9 9 5 9 9 9
 8 8 8 0 P 8 8 8 8 8 8 0 8 8 8 0 8 8 9
 0 0 0 1 1 0 0 1 1 1 1 2 1 2 2 4 3 3 3
 2 3 5 7 7 6 8 0 2 4 6 8 8 4 8 0 2 6 6

REF. PART NBR

DESCRIPTION

03	605488-025	LIGHT LEAD COMPLETE CAT L9 (IEC CONSTRUCTION)	X	X	X	-	-	X	X	X	X	X	X	-	X	X	X	-	-	X	-
04	179908	LIGHT LEAD GROMMET	X	X	X	X	X	X	X	X	X	X	X	X	X	X	X	X	X	X	X
07	988076-001	LAMP (120V)	-	-	X	X	X	-	-	X	X	X	-	X	X	-	-	X	X	X	X
07	988076-003	LAMP (220/250V)	X	X	X	-	-	X	X	X	X	X	-	X	X	X	-	X	X	X	X
08	354592-451	LIGHT SOCKET MOUNTING SCREW	X	X	X	X	X	X	X	X	X	X	X	X	X	X	X	X	X	X	X
09		REFER TO CHARTS ON FOLLOWING PAGES																			
10		REFER TO CHARTS ON FOLLOWING PAGES																			
11		REFER TO CHARTS ON FOLLOWING PAGES																			
12		REFER TO CHARTS ON FOLLOWING PAGES																			
13	179901	HEAT SHIELD (WITHOUT GRAPHICS)	X	X	X	X	X	X	X	X	X	X	X	X	X	X	X	X	X	X	X
13	179910-451	LIGHT SHIELD (WITH GRAPHICS) (FOR US/CANADA)	-	-	X	X	X	-	-	X	X	X	-	X	X	-	-	X	X	X	-
14	605087-001	HEAT SHIELD (FOR EUROPE)	X	X	X	-	-	X	X	X	X	X	X	-	X	X	-	X	X	-	
17	362264-901	MOTOR MOUNTING PLATE CLAMP SCREW	X	X	X	X	X	X	X	X	X	X	X	X	X	X	X	X	X	X	X
18	113370-451	MOTOR MOUNTING PLATE SCREW (LOWER)	X	X	X	X	X	X	X	X	X	X	X	X	X	X	X	X	X	X	X
19	356803-901	MOTOR MOUNTING PLATE	X	X	X	X	X	X	X	X	X	X	X	X	X	X	X	X	X	X	X
20	353518-001	MOTOR BELT (V)	X	X	X	X	X	X	X	X	X	X	X	X	X	X	X	X	X	X	X
21		REFER TO CHARTS ON FOLLOWING PAGES																			
22		REFER TO CHARTS ON FOLLOWING PAGES																			
23	313470-452	MOTOR MOUNTING PLATE SCREW NUT	X	X	X	X	X	X	X	X	X	X	X	X	X	X	X	X	X	X	X
25	988761-001	MOTOR PULLEY	X	X	X	X	X	X	X	X	X	X	X	X	X	X	X	X	X	X	X
26		REFER TO CHARTS ON FOLLOWING PAGES																			
27	605600-004	TYE RAP	X	X	X	X	X	X	X	X	X	X	X	X	X	X	X	X	X	X	X
31	362237-901	MOTOR MOUNTING PLATE SPACER	X	X	X	X	X	X	X	X	X	X	X	X	X	X	X	X	X	X	X
32	362263-901	MOTOR MOUNTING PLATE SPACER SCREW	X	X	X	X	X	X	X	X	X	X	X	X	X	X	X	X	X	X	X
33	113372-451	MOTOR MOUNTING PLATE SCREW (UPPER)	X	X	X	X	X	X	X	X	X	X	X	X	X	X	X	X	X	X	X

From the library of: Niagara Nuclear Corp

ELECTRICAL EQUIPMENT

		U.S	CANADA	EUROPE	GREAT BRITAIN
REF.	1 SPEED UNSUPRESSED	(120V)	(120V)	(220V)	(240V)
12	LIGHT COMPLETE	362160-002	362160-002		
21	MOTOR COMPLETE	362180-012	362180-012		
22	SERIES MOTOR MODULE	988752-010	988752-010		
26	COMUTATOR END	362239-012	362239-012		
10	CONTROLLER	362095-001	362095-001		
09	SWITCH COMPLETE	362307-003	362307-003		
11	LIGHT CONNECTOR HARNESS	988764-003	988764-003		
REF.	1 SPEED SUPRESSED				
03	LIGHT COMP.			605488-025	605488-025
21	MOTOR COMPLETE			362180-016	362180-016
22	SERIES MOTOR MODULE			988752-011	988752-011
26	COMUTATOR END			362239-016	362239-016
10	CONTROLLER			362095-002	362095-015
9	SWITCH COMPLETE			988763-004	988763-004
11	LIGHT CONNECTOR HARNESS			988768-003	988768-003

From the library of: Diamond Needle Corp

 REV.: _____
 DATA: DEC/98

ELECTRICAL EQUIPMENT

		ASIA & AFRICA & SOUTH AMERICA	ASIA & AFRICA & SOUTH AMERICA	AFRICA & SOUTH AMERICA	AMEDO
REF.	1 SPEED UNSUPRESSED	FLAT BLADE (120V)	FLAT BLADE (220V)	ROUND PIN (120V)	ROUND PIN (220V)
12	LIGHT COMPLETE	362001-007	362001-007	362001-007	362001-007
21	MOTOR COMPLETE	362180-013	362180-014	362180-013	362180-014
22	SERIES MOTOR MODULE	362207-005	362207-006	362207-005	362207-006
26	COMUTATOR END	362239-013	362239-014	362239-013	362239-014
10	CONTROLLER	362095-007	362095-008	362095-005	362095-006
09	SWITCH COMPLETE	362307-001	362307-001	362307-001	362307-001
11	LIGHT CONNECTOR HARNESS	988764-005	988764-005	988764-005	988764-005

From the library of: Diamond Needle Corp

REV.:

DATA: DEC/98

ELECTRICAL EQUIPMENT

		AFRICA & SOUTH AMERICA	SOUTH AFRICA	AUSTRALIA
REF	1 SPEED UNSUPRESSED	ROUND PIN (220V)	ROUND PIN (220V)	(240V)
12	LIGHT COMPLETE	362001-007	362001-007	
21	MOTOR COMPLETE	362180-014	362180-013	
22	SERIES MOTOR MODULE	362207-006	362207-005	
26	COMUTATOR END	362239-014	362239-013	
10	CONTROLLER	362095-006	362095-005	
09	SWITCH COMPLETE	362307-001	362307-001	
11	LIGHT CONNECTOR HARNESS	988764-005	988764-005	
REF.	1 SPEED SUPRESSED			
03	LIGHT COMPLETE			605488-025
21	MOTOR COMPLETE			362180-016
22	SERIES MOTOR MODULE			988752-011
26	COMUTATOR END			362239-016
10	CONTROLLER			362095-010
09	SWITCH - 2 SPEED			988763-004
11	LIGHT CONNECTOR HARNESS			988768-003

From the library of: Diamond Needle Corp

REV: _____
 DATA: DEC/98